



# DiamondBack™

## GTAW Weldheads



The DiamondBack™ is our largest in-place orbital weldhead. Heavy duty and versatile, the DiamondBack™ has a narrow profile and is perfect for process piping and weld fitting applications found in food & beverage, dairy and other sanitary process piping installations. Also great for high-pressure aerospace applications, this easy to use weldhead is simple yet robust to meet the demands of field construction or manufacturing production environments.

- Weldable Tube Range: 2" Tube OD to 6" Tube OD
- Weldable Nominal Pipe Range: 2" Nominal Pipe to 5" Nominal Pipe.
- 3-Piece Collet Design for Precision Self-Centering of Tube or Pipe.
- Operator Flexibility: Flip-Top and View Lens aid Fit-Up, Alignment & Inspection.
- Ergonomically Perfect with 7 Function, Push Button Fingertip Control Built into the Weldhead.
- Advanced Design includes Jaw Style Clamping, 360° Head Rotation and 90° Tilt Action. Rugged Machined Aluminum Handles Eliminates Handling of Weldhead Body.
- Weld fitting collets, mandrels and special tooling available.
- Standard cable lengths of 25ft (7.6m).

### Popular Accessories

- DiamondBack™ Benchmount Kit (P/N 005-0680)
- 25 ft (7.6m) Extension Cable (P/N 005-0635)
- 50 ft (15.2m) Extension Cable (P/N 005-0635-50)

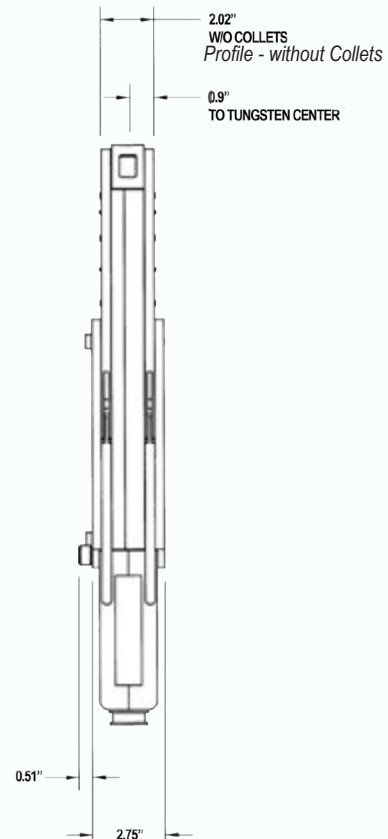
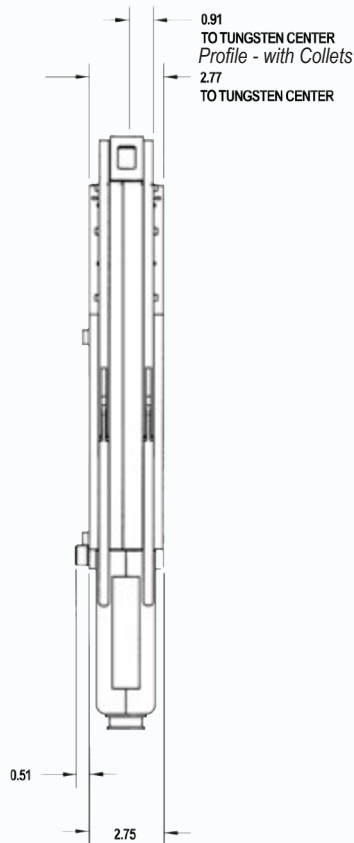

MODEL	DESCRIPTION	DIAMETER RANGE	COOLING REQUIREMENTS
5006	DiamondBack™	2" O.D. ~ 6" O.D.	No