



PYTHON[®]

Euro Compatible™ 7 Pin

Owner's Manual

Product:	Python
Manual:	091-0643
Serial:	12010001
Voltage Rating:	24 VDC
Revision:	Jan 2012 Rev A
Gun models:	296-8XX 297-8XX



**225 Ampere Air Cooled
450 Ampere Water Cooled
Push-Pull Welding Guns**

Table of Contents

Safety Considerations i-iii

Installation Section A

 Technical Specifications 1

 Support Equipment Required 1

 Gun Lead Connections 1

Operation Section B

 General 2

 Controls and Settings 2

 Trigger Adjustment 2

 Drive Roll and Idler Rolls 3

Accessories Section C

 Optional Kits 4

 Snake Skins 4

 Contact Tips 5

 Gas Cups 5

 Barrels 6

Maintenance Section D

 Periodic Maintenance 7

 Recommended Spare Parts List 8

Troubleshooting Section E

 Troubleshooting Guide 9

 Testing The Gun 9

Appendices Section F

 Diagrams / Parts List 11

 Mechanical 12

 Electrical 29

Safety Warnings

Warranty

Declaration of Conformity for European Community (CE) Products

Note  This information is provided for units with CE certification (see rating label on unit).

Manufacturer's Name: **MK Products, Inc.**
16882 Armstrong Ave.
Irvine, CA 92606

Declares that the product: **Python® Euro Compatible™ 7 Pin**
conforms to the following Directives and Standards:

Directives

Low Voltage Directive: 2006/95/EC

Electromagnetic Compatibility (EMC) Directive: 2004/108/EC

Standards

Electromagnetic Compatibility, (EMC): EN 60974-10: 2007

Torches And Guns For Arc Welding, EN 60974-7: 2005

SAFETY CONSIDERATIONS

ELECTRIC ARC WELDING EQUIPMENT

CAUTION : READ BEFORE ATTEMPTING INSTALLATION, OPERATION OR MAINTENANCE OF THIS EQUIPMENT

1-1 INTRODUCTION

This equipment is intended for ultimate application by commercial/industrial users and for operation by persons trained and experienced in the use and maintenance of welding equipment. Operation should not be undertaken without adequate training in the use of such equipment. Training is available from many public and private schools or similar facilities.

Safe practices in the installation, operation and maintenance of this equipment requires proper training in the art, a careful study of the information provided with the equipment, and the use of common sense. Rules for safe use are generally provided by suppliers of welding power sources, compressed gas suppliers, and electrode suppliers. Careful compliance with these rules will promote safe use of this equipment.

The following Safety Rules cover some of the more generally found situations. READ THEM CAREFULLY. In case of any doubt, obtain qualified help before proceeding.

1-2 GENERAL PRECAUTIONS

A. Burn Prevention

ELECTRIC ARC WELDING PRODUCES HIGH INTENSITY HEAT AND ULTRAVIOLET RADIANT ENERGY WHICH MAY CAUSE SERIOUS AND PERMANENT EYE DAMAGE AND WHICH MAY DAMAGE ANY EXPOSED SKIN AREAS.

Wear helmet with safety goggles or glasses with side shields underneath, appropriate filter lenses or plates (protected by clear cover glass). This is a must for welding or cutting (and chipping) to protect the eyes from radiant energy and flying metal. Replace cover glass when broken, pitted, or spattered.

Medical first aid and eye treatment. First aid facilities and a qualified first aid person should be available for each shift unless medical facilities are close by for immediate treatment of flash burns of the eyes and skin burns.

Wear protective clothing - leather (or asbestos) gauntlet gloves, hat, and high safety-toe shoes. Button shirt collar and pocket flaps, and wear cuffless trousers to avoid entry of sparks and slag.

Avoid oily or greasy clothing. A spark may ignite them.

Flammable hair preparations should not be used by persons intending to weld or cut.

Hot metal such as electrode stubs and

work pieces should never be handled without gloves.

Ear plugs should be worn when working on overhead or in a confined space. A hard hat should be worn when others work overhead.

B. Toxic Fume Prevention

WARNING: The use of this product may result in exposure to chemicals known to the State of California to cause cancer and birth defects or other reproductive harm.

Adequate ventilation. Severe discomfort, illness or death can result from fumes, vapors, heat, or oxygen enrichment or depletion that welding (or cutting) may produce. Prevent them with adequate ventilation. NEVER ventilate with oxygen.

Lead-, cadmium-, zinc-, mercury-, beryllium-bearing and similar materials, when welded or cut, may produce harmful concentrations of toxic fumes. Adequate local exhaust ventilation must be used, or each person in the area, as well as the operator, must wear an air-supplied respirator. For beryllium, both must be used.

Metals coated with or containing materials that emit toxic fumes should not be heated unless coating is removed from the work surface, the area is well ventilated, or the operator wears an air-supplied respirator.

Work in a confined space only while it is being ventilated and, if necessary, while wearing an air-supplied respirator.

Gas leaks in a confined space should be avoided. Leaked gas in large quantities can change oxygen concentration dangerously. Do not bring gas cylinders into a confined space.

Leaving confined space, shut OFF gas supply at source to prevent possible accumulation of gases in the space if downstream valves have been accidentally opened or left open. Check to be sure that the space is safe before reentering it.

Vapors from chlorinated solvents can be decomposed by the heat of the arc (or flame) to form PHOSGENE, a highly toxic gas, and other lung and eye irritating products. The ultraviolet (radiant) energy of the arc can also decompose trichloroethylene and perchloroethylene vapors to form phosgene. DO NOT WELD or cut where solvent vapors can be drawn into the welding or cutting atmosphere or where the radiant energy can penetrate to atmospheres containing even minute amounts of trichloroethylene or perchloroethylene.

C. Fire and Explosion Prevention

Causes of fire and explosion are: combustibles reached by the arc, flame, flying sparks, hot slag, or heated material, misuse

of compressed gases and cylinders, and short circuits.

BE AWARE THAT flying sparks or falling slag can pass through cracks, along pipes, through windows or doors, and through wall or floor openings, out of sight of the goggled operator. Sparks can fly many feet.

To prevent fires and explosion:

Keep equipment clean and operable, free of oil, grease, and (in electrical parts) of metallic particles that can cause short circuits.

If combustibles are in area, do NOT weld or cut. Move the work if practicable, to an area free of combustibles. Avoid paint spray rooms, dip tanks, storage areas, ventilators. If the work cannot be moved, move combustibles at least 35 feet away, out of reach of sparks and heat; or protect against ignition with suitable and snug-fitting, fire-resistant covers or shields.

Walls touching combustibles on opposite sides should not be welded on (or cut). Walls, ceilings, and floor near work should be protected by heat-resistant covers or shields.

Fire watcher must be standing by with suitable fire extinguishing equipment during and for some time after welding or cutting if:

1. Appreciable combustibles (including building construction) are within 35 feet.
2. Appreciable combustibles are further than 35 feet, but can be ignited by sparks.
3. Openings (concealed or visible) in floors or walls within 35 feet may expose combustibles to sparks.
4. Combustibles adjacent to walls, ceilings, roofs, or metal partitions can be ignited by radiant or conducted heat.

Hot work permit should be obtained before operation to ensure supervisor's approval that adequate precautions have been taken.

After work is done, check that area is free of sparks, glowing embers, and flames.

An empty container that held combustibles, or that can produce flammable or toxic vapors when heated, must never be welded on or cut, unless container has first been cleaned in accordance with industry standards.

This includes: a thorough steam or caustic cleaning (or a solvent of water washing, depending on the combustible's solubility), followed by purging and inerting with nitrogen or carbon dioxide, and using protective equipment.

Water-filling just below working level may substitute for inerting.

A container with unknown contents should be cleaned (see paragraph above). Do NOT depend on sense of smell or sight to determine if it is safe to weld or cut.

Hollow castings or containers must be vented before welding or cutting. They can explode.

Explosive atmospheres. NEVER weld or cut where the air may contain flammable dust, gas, or liquid vapors (such as gasoline).

D. Compressed Gas Equipment

The safe handling of compressed gas equipment is detailed in numerous industry publications. The following general rules cover many of the most common situations.

1. Pressure Regulators

Regulator relief valve is designed to protect only the regulator from overpressure; it is not intended to protect any downstream equipment. Provide such protection with one or more relief devices.

Never connect a regulator to a cylinder containing gas other than that for which the regulator was designed.

Remove faulty regulator from service immediately for repair (first close cylinder valve). The following symptoms indicate a faulty regulator:

Leaks - if gas leaks externally.

Excessive Creep - if delivery pressure continues to rise with downstream valve closed.

Faulty Gauge - if gauge pointer does not move off stop pin when pressurized, nor returns to stop pin after pressure release.

Repair. Do NOT attempt repair. Send faulty regulators for repair to manufacturer's designated repair center, where special techniques and tools are used by trained personnel.

2. Cylinders

Cylinders must be handled carefully to prevent leaks and damage to their walls, valves, or safety devices:

Avoid electrical circuit contact with cylinders including third rails, electrical wires, or welding circuits. They can produce short circuit arcs that may lead to a serious accident. (See 1-3C)

ICC or DOT marking must be on each cylinder. It is an assurance of safety when the cylinder is properly handled.

Identifying gas content. Use only cylinders with name of gas marked on them; do not rely on color to identify gas content. Notify supplier if unmarked. NEVER DEFACE or alter name, number, or other markings on a cylinder. It is illegal and hazardous.

Empties: Keep valves closed, replace caps securely; mark MT; keep them separate from FULLS, and return promptly.

Prohibited use. Never use a cylinder or

its contents for other than its intended use, NEVER as a support or roller.

Locate or secure cylinders so they cannot be knocked over.

Passageways and work areas. Keep cylinders clear of areas where they may be stuck.

Transporting cylinders. With a crane, use a secure support such as a platform or cradle. Do NOT lift cylinders off the ground by their valves or caps, or by chains, slings, or magnets.

Do NOT expose cylinders to excessive heat, sparks, slag, and flame, etc. that may cause rupture. Do not allow contents to exceed 55 degrees C (130 degrees F.) Cool with water spray where such exposure exists.

Protect cylinders, particularly valves from bumps, falls, falling objects, and weather. Replace caps securely when moving cylinders.

Stuck valve. Do NOT use a hammer or wrench to open a cylinder valve that cannot be opened by hand. Notify your supplier.

Mixing gases. NEVER try to mix any gases in a cylinder.

NEVER refill any cylinder.

Cylinder fittings should never be modified or exchanged.

3. Hose

Prohibited use. Never use hose other than that designed for the specified gas. A general hose identification rule is: red for fuel gas, green for oxygen, and black for inert gases.

Use ferrules or clamps designed for the hose (not ordinary wire or other substitute) as a binding to connect hoses to fittings.

No copper tubing splices. Use only standard brass fittings to splice hose.

Avoid long runs to prevent kinks and abuse. Suspend hose off ground to keep it from being run over, stepped on, or otherwise damaged.

Coil excess hose to prevent kinks and tangles.

Protect hose from damage by sharp edges, and by sparks, slag, and open flame.

Examine hose regularly for leaks, wear, and loose connections. Immerse pressured hose in water; bubbles indicate leaks

Repair leaky or worn hose by cutting area out and splicing. Do NOT use tape.

4. Proper Connections

Clean cylinder valve outlet of impurities that may clog orifices and damage seats before connecting regulator. Except for hydrogen, crack valve momentarily, pointing outlet away from people and sources of ignition. Wipe with a clean, lintless cloth.

Match regulator to cylinder. Before connecting, check that the regulator label and cylinder marking agree, and that the regulator inlet and cylinder outlet match. NEVER Connect a regulator designed for a particular gas or gases to a cylinder containing any other gas.

Tighten connections. When assembling threaded connections, clean and smooth seats where necessary. Tighten. If connection leaks, disassemble, clean, and retighten, using properly fitting wrench.

Adapters. Use a CGA adapter (available from your supplier) between cylinder and regulator, if one is required. Use two wrenches to tighten adapter marked RIGHT and LEFT HAND threads.

Regulator outlet (or hose) connections may be identified by right hand threads for oxygen and left hand threads (with grooved hex on nut or shank) for fuel gas.

5. Pressurizing Steps:

Drain regulator of residual gas through suitable vent before opening cylinder (or manifold valve) by turning adjusting screw in (clockwise). Draining prevents excessive compression heat at high pressure seat by allowing seat to open on pressurization. Leave adjusting screw engaged slightly on single-stage regulators.

Stand to side of regulator while opening cylinder valve.

Open cylinder valve slowly so that regulator pressure increases slowly. When gauge is pressurized (gauge reaches regulator maximum) leave cylinder valve in following position: for oxygen and inert gases, open fully to seal stem against possible leak; for fuel gas, open to less than one turn to permit quick emergency shut-off.

Use pressure charts (available from your supplier) for safe and efficient recommended pressure settings on regulators.

Check for leaks on first pressurization and regularly thereafter. Brush with soap solution. Bubbles indicate leaks. Clean off soapy water after test; dried soap is combustible.

E. User Responsibilities

Follow all Safety Rules.

Remove leaky or defective equipment from service immediately for repair. Read and follow user manual instructions.

F. Leaving Equipment Unattended

Close gas supply at source and drain gas.

G. Rope Staging-Support

Rope staging-support should not be used for welding or cutting operation; rope may burn.

1-3 ARC WELDING

Comply with precautions in 1-1, 1-2, and this section. Arc Welding, properly done, is a safe process, but a careless operator invites trouble. The equipment carries high currents at significant voltages. The arc is very bright and hot. Sparks fly, fumes rise, ultraviolet and infrared energy radiates, weldments are hot, and compressed gases may be used. The wise operator avoids unnecessary risks and protects himself and others from accidents.

A. Burn Protection

Comply with precautions in 1-2.

The welding arc is intense and visibly bright. Its radiation can damage eyes, penetrate lightweight clothing, reflect from light-colored surfaces, and burn the skin and eyes. Skin burns resemble acute sunburn; those from gas-shielded arcs are more severe and painful. **DON'T GET BURNED; COMPLY WITH PRECAUTIONS.**

1. Protective Clothing

Wear long-sleeve clothing in addition to gloves, hat, and shoes. As necessary, use additional protective clothing such as leather jacket or sleeves, flameproof apron, and fire-resistant leggings. Avoid outer garments of untreated cotton.

Bare skin protection. Wear dark, substantial clothing. Button collar to protect chest and neck, and button pockets to prevent entry of sparks.

2. Eye and Head Protection

Protect eyes from exposure to arc. Eyes may be damaged by radiant energy when exposed to the electric arc, even when not looking in the direction of the arc. Never look at an electric arc without protection.

Welding helmet or shield containing a filter plate shade no. 12 or denser must be used when welding. Place over face before striking arc.

Protect filter plate with a clear cover plate.

Cracked or broken helmet or shield should NOT be worn; radiation can be passed through to cause burns.

Cracked, broken, or loose filter plates must be replaced IMMEDIATELY. Replace clear cover plate when broken, pitted, or spattered.

Flash goggles with side shields MUST be worn under the helmet to give some protection to the eyes should the helmet not be lowered over the face before an arc is struck. Looking at an arc momentarily with unprotected eyes (particularly a high intensity gas-shielded arc) can cause a retinal burn that may leave a permanent dark area in the field of vision.

3. Protection of Nearby Personnel

Enclose the welding area. For production welding, a separate room or enclosed bay is best. In open areas, surround the operation with low-reflective, noncombustible screens or panels. Allow for free air circulation, particularly at floor level.

Viewing the weld. Provide face shields for all persons who will be looking directly at the weld.

Others working in area. See that all persons are wearing flash goggles.

Before starting to weld, make sure that screen flaps or bay doors are closed.

B. Toxic Fume Prevention

Comply with precautions in 1-2B.

Generator engine exhaust must be vented to the outside air. Carbon monoxide can kill.

C. Fire and Explosion Prevention

Comply with precautions in 1-2C.

Equipment's rated capacity. Do not overload arc welding equipment. It may overheat cables and cause a fire.

Loose cable connections may overheat or flash and cause a fire.

Never strike an arc on a cylinder or other pressure vessel. It creates a brittle area that can cause a violent rupture or lead to such a rupture later under rough handling.

D. Compressed Gas Equipment

Comply with precautions in 1-2D.

E. Shock Prevention

Exposed electrically hot conductors or other bare metal in the welding circuit, or in ungrounded, electrically - HOT equipment can fatally shock a person whose body becomes a conductor. **DONOT STAND, SIT, LIE, LEAN ON, OR TOUCH** a wet surface when welding without suitable protection.

To protect against shock:

Keep body and clothing dry. Never work in damp area without adequate insulation against electrical shock. Stay on a dry duckboard, or rubber mat when dampness or sweat cannot be avoided. Sweat, sea water, or moisture between body and an electrically HOT part - or grounded metal - reduces the body surface electrical resistance, enabling dangerous and possibly lethal currents to flow through the body.

1. Grounding the Equipment

When installing, connect the frames of each unit such as welding power source, control, work table, and water circulator to the building ground. Conductors must be adequate to carry ground currents safely. Equipment made electrically HOT by stray currents may shock, possibly fatally. Do NOT GROUND to electrical conduit, or to a pipe carrying ANY gas or a flammable liquid such as oil or fuel.

Three-phase connection. Check phase requirement of equipment before installing. If only three-phase power is available, connect single-phase equipment to only two wires of the three-phase line. Do NOT connect the equipment ground lead to the third (live) wire, or the equipment will become electrically HOT - a dangerous condition that can shock, possibly fatally.

Before welding, check ground for continuity. Be sure conductors are touching bare metal of equipment frames at connections.

If a line cord with a ground lead is provided with the equipment for connection to a switch box, connect the ground lead to the grounded switch box. If a three-prong plug is added for connection to a grounded mating receptacle, the ground lead must be connected to the ground prong only. If the line cord comes with a three-prong plug, connect to a grounded mating receptacle. Never remove the ground prong from a plug, or use a plug with a broken ground prong.

2. Connectors

Fully insulated lock-type connectors should be used to join welding cable lengths.

3. Cables

Frequently inspect cables for wear, cracks, and damage. IMMEDIATELY REPLACE those with excessively worn or damaged insulation to avoid possibly lethal shock from bared cable. Cables with damaged areas may be taped to give resistance equivalent to original cable.

Keep cable dry, free of oil and grease, and protected from hot metal and sparks.

4. Terminals and Other Exposed Parts

Terminals and other exposed parts of electrical units should have insulating covers secured before operation.

5. Electrode Wire

Electrode wire becomes electrically HOT when the power switch of gas metal-arc welding equipment is ON and welding gun trigger is pressed. Keep hands and body clear of wire and other HOT parts.

6. Safety Devices

Safety devices such as interlocks and circuit breakers should not be disconnected or shunted out.

Before installation, inspection, or service of equipment, shut OFF all power, and remove line fuses (or lock or red-tag switches) to prevent accidental turning ON of power. Disconnect all cables from welding power source, and pull all 115 volts line-cord plugs.

Do not open power circuit or change polarity while welding. If, in an emergency, it must be disconnected, guard against shock burns or flash from switch arcing.

Leaving equipment unattended. Always shut OFF, and disconnect all power to equipment.

Power disconnect switch must be available near the welding power source.

Thank You

For selecting a quality product. We want you to take pride in operating this product...as much pride as we have in bringing the product to you!

Please Examine Carton and Equipment For Damage Immediately

When this equipment is shipped, title passes to the purchaser upon receipt by the carrier. Consequently, claims for material damaged in shipment must be made by the purchaser against the transportation company at the time the shipment is received.

Please record your equipment identification information below for future reference. This information can be found on your machine nameplate.

Model Name & Number _____

Code & Serial Number _____

Date of Purchase _____

Whenever you request replacements parts for, or information on this equipment always supply the information you have recorded above.

Read this Owner's Manual completely before attempting to use this equipment. Save this manual and keep it handy for quick reference. Pay particular attention to the safety instructions we have provided for your protection.

Section A



Installation

Technical Specifications

Wire Capacity

.030" - .045" (0.6mm - 1.2mm) solid and hard wire

.030" - 1/16" (0.8mm - 1.6mm) aluminum and cored wire

Wire Speed

800 IPM (20.3 mpm) Max. at rated feeder Input Voltage (120VAC / 42VAC)

Duty Cycle - 60% (*All ratings are using Argon Gas*)

225 Amps/25 Volts Air Cooled

450 Amps/25 Volts Water Cooled

Support Equipment Required

- C.V. or C.C. Power Source of sufficient capacity for your needs.
- Regulated gas supply and hoses.
- Properly sized power leads from power source to wire feeder and ground.
- Water source and hose capable of providing a minimum of **1 quart (.95 liter) / min. at 45 p.s.i.** when using water cooled guns.

Coolant Recommendations

Use Cobra Coolant (Aluminum Protection), P/N 931-0060. Cobra Coolant does not contain reactive sulphur or chlorine and does not react with copper, brass or aluminum.

The coolant flow rate should be a minimum of 15 GPH (1 qt/min) between 35 and 45psi. Contact the re-circulator manufacturer for specifications on pressure.

Gun Lead Connections

Power Cable - Air Cooled

A #2 power cable is used on the Python Euro Compatible 7 Pin gun. The gun and Euro Power Manifold ends of the cable are stripped to the copper strands and wrapped with a copper strip. A setscrew holds the cable securely in the gun body and in the Euro Power Manifold with torque requirements of 55-60 in-lb.

Power Cable - Water Cooled

Python Euro Compatible 7 Pin water cooled gun utilizes a power/water cable with a #6 AWG cable inside a 5/16" diameter hose. When water is used with this cable and the #10 water cooled gas cup (P/N 621-0065), the system is rated at 450 amps @ 60% duty cycle. The gun end is threaded into the gun body. These connections utilize a conductive sealant and are tightened with torque requirements of 100 ± 5 IN-LB.

Conduit

The Python Euro Compatible 7 Pin comes standard with a poly-lined conduit, for feeding aluminum wire. The longer fitting with a shallow groove is used on the gun end. A set screw located on top of the gun handle secures the conduit in place. The cabinet end of the conduit is secured into the Euro Power Manifold connector with a set screw.

Gas Hose

The BLACK gas hose is pushed over a barbed fitting on the end of the gun body and secured by twisting the hose retainer to the end of the hose (shown next page). The opposite end of the BLACK hose is pushed over a barbed fitting in the Euro Power Manifold. The hose retainer is re-usable and can be removed and re-installed as needed.



Coolant Connections

If so equipped, the ends of the coolant hose push over a barbed fitting on the end of the gun body and are secured by twisting the hose retainer to the end of the hose. The hose retainer is re-usable and can be removed and re-installed as needed.

The BLUE coolant supply hose pushes over a barbed fitting on the end of the gun body and is secured by twisting the hose retainer to the end of the hose. The hose retainer is re-usable and can be removed and re-installed as needed. The opposite end of the BLUE hose pushes into a threaded coolant fitting.

The RED coolant return hose pushes over the barbed fitting in the Power Manifold. The opposite end of the RED hose pushes into a threaded return hose of the coolant recirculator.

Both the BLUE and RED threaded fittings on the end of the BLUE and RED hoses, are standard left-hand thread. MK Products compatible guns have interchangeable fittings, so you can match as needed for your cooler. Both types of fittings require a hose retainer.



431-1898
5/16" Hose Retainer



431-1910
Quick Connect Fitting



431-1893*
Nipple



753-3379*
Left-Hand Threaded Fitting
**Must be ordered together*

Control Cable

A multi-conductor control cable is used on the Python Euro Compatible 7 Pin. The gun end of the cable is secured with a cable clamp and the wires are connected to the potentiometer, the micro switch, the motor and the gun body mechanically. Slack is left in the electric cable as it exits the back of the gun to prevent cable and/or wire breakage. The cabinet end has a seven pin "W" clocked amphenol connector.

Section B

Operation

General

The Python Euro Compatible 7 Pin gun maintains a constant, steady, uniform wire feed speed, regardless of curved or looped wire conduit. The constant push exerted by the slave motor in the cabinet, combined with the pull of the gun motor, causes the wire to literally float friction-free through the wire conduit. The 24VDC gun motor is controlled by a three and three-quarter (3 3/4) turn potentiometer in the gun handle.

Controls and Settings

Potentiometer

The laterally-positioned potentiometer is located in the lower end of the handle, providing up to 800 ipm with 3 3/4 turns.

Micro Switch

The micro switch assembly consists of the micro switch, and leads.

Trigger Sensitivity

The amount of trigger level travel can be shortened for a "quicker" or "more responsive" action.

A more sensitive trigger lever is produced by reducing the gap between the trigger lever and the micro-



switch lever. By turning-in the Trigger Sensitivity Adjustment Screw, it closed the gap between the trigger lever and the micro-switch lever.

This will enable the operator to increase the sensitivity of the trigger lever.

Sensitivity Adjustment

With the wire feeder turned on (with or without welding wire loaded), turn the screw in until the micro-switch is activated. Once activated, the gun and wire feeder motors will begin feeding wire. Retract the screw accordingly until the system is deactivated and adjusted to the operators' liking.

Drive Roll and Idler Rolls

General

The Python Euro Compatible 7 Pin gun comes standard with a knurled drive roll and a grooved idler roll, which will handle aluminum wire with diameters of .030 to 1/16 inch and steel from .030 to .045 inches. Optional insulated V-groove drive rolls are also available for aluminum wire if desired (see Optional Kits).

Drive roll tension is accomplished with a unique spring-loaded pressure screw. The Python Euro Compatible 7 Pin comes from the factory with the pressure adjustment screw preset. **NO ADJUSTMENT IS REQUIRED FOR ALL SIZES AND TYPES OF WIRES.**

Drive Roll Installation/Removal

NOTE: Neither of the handles needs to be removed to access the Drive or Idler Rolls.

1. Pull the Cam Lever away from the idler roll. This will relieve the pressure against the drive roll (as shown in Figure 1).
2. Align the Drive Roll Removal Tool (P/N 931-0100)



Figure 1

over the flats of the drive roll (as shown in Figure 2). Hold the gun with one hand or on a table top, with the other hand give the Removal Tool a quick snap-turn in the **CLOCKWISE DIRECTION.**



Figure 2

3. Once the drive roll is loose, continue to spin drive roll in the clockwise direction to remove the drive roll from the gun.
4. Install a new drive roll on the left-hand threaded shaft. The drive roll will self-tighten when it is feeding wire.

Idler Roll Installation and Removal

(Reference Figure 3)

1. Using a slot type screwdriver, loosen idler screw, taking care not to lose lock washer under idler roll.
2. Insert new idler roll and lock washer onto screw, insuring that idler groove is toward top and lock washer is beneath.
3. Tighten.

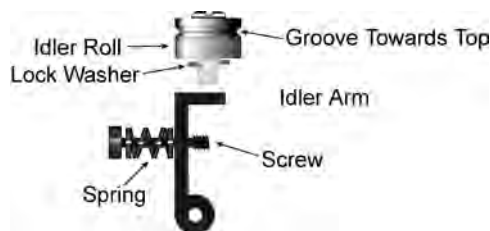

Figure 3

NOTE: Lock washer must be under idler roll or it will not turn freely.

Section C

Accessories/Options

Insulated Drive Roll Kits are used to prevent preheating of the wire which may soften it and clog the liner. This picking up of current at the drive rolls rather than at the contact tip is usually not a problem unless using too large of a contact tip or excessively oxidized aluminum wire.

Insulated Groove Drive Roll Kit..... 005-0715

For **.030"** (0.8mm) dia. aluminum wire. Includes insulated groove drive roll and insulated idler roll assy.

Insulated Groove Drive Roll Kit..... 005-0716

For **.035"** (0.9mm) dia. aluminum wire. Includes insulated groove drive roll and insulated idler roll assy.

Insulated Groove Drive Roll Kit..... 005-0717

For **.040"** (1.0mm) dia. aluminum wire. Includes insulated groove drive roll and insulated idler roll assy.

Insulated Groove Drive Roll Kit..... 005-0718

For **3/64"** (1.2mm) dia. aluminum wire. Includes insulated groove drive roll and insulated idler roll assy.

Insulated Groove Drive Roll Kit..... 005-0719

For **.062"** (1.6mm) dia. aluminum wire. Includes insulated groove drive roll and insulated idler roll assy.

Handle Kit.....005-0699

Includes left and right handles, screws and drive roll door.

Trigger Kit.....005-0694

Trigger adjustment kit includes a spring and sensitivity adjustment screw replacement for all Python Euro Compatible 7 Pin guns.

Micro Switch Kit.....005-0701

Replacement micro switch assembly for all Python Euro Compatible 7 Pin guns.

Potentiometer Kit.....005-0695

Replacement potentiometer assembly for all Python Euro Compatible 7 Pin guns.

Conduits

Flat Spiral Steel Conduit for steel and cored wire. Standard with teflon liner.

615-0621-15 15ft./4.5m

615-0621-25 25ft./7.6m

615-0621-35 35ft/10.7m

615-0621-50 50ft./15.2m

Optional nickle tube liner..... 003-2281

Snake Skins®

Snake Skin® protective covers are now standard on all guns. You may order spare replacement covers to protect the lead assy of the gun when the factory one becomes damaged or worn. It can easily be replaced in the field by means of Velcro®.

Snake Skin Cover 13ft (for 15ft leads) **931-0110**

Snake Skin Cover 23ft (for 25ft leads) **931-0122**

Snake Skin Cover 33ft (for 35ft leads) **931-0132**

Snake Skin Cover 48ft (for 50ft leads) **931-0123**

Contact Tips



To remove contact tip when using full water cooled gas cup (P/N 621-0065), contact tip removal tool (P/N 931-0044) must be used.

Heavy Duty Contact Tip - 3/8" Diameter*				
Wire Size	Tip ID	Arc	Tip Length	Part No.
.030" (0.8mm)	.041" (1.0mm)	Spray	1.57" (39.9mm)	621-0390-25
		Short	1.82" (46.2mm)	621-0396-25
.035" (0.9mm)	.044" (1.1mm)	Spray	1.57" (39.9mm)	621-0391-25
				621-0391-250 [†]
				621-0391-500 ^{††}
.035" (0.9mm)	.044" (1.1mm)	Short	1.82" (46.2mm)	621-0397-25
.045" (1.1mm)	.053" (1.35mm)	Short	1.82" (46.2mm)	621-0398-25
3/64" (1.2mm)	.053" (1.35mm)	Spray	1.57" (39.9mm)	621-0392-25
				621-0392-250 [†]
				621-0392-500 ^{††}
3/64" (1.2mm)	.060" (1.5mm)	Spray	1.57" (39.9mm)	621-0393-25**
				621-0393-250 [†]
				621-0393-500 ^{††}
1/16" (1.6mm)	.074" (1.9mm)	Spray	1.57" (39.9mm)	621-0394-25
		Spray		621-0395-25

*Use of tip removal tool is recommended

[†] Also sold in quantities of 250

**This size tip furnished with gun

^{††} Also sold in quantities of 500



Spring Loaded Contact Tip - 3/8" Diameter					
Wire Size	Tip ID	Arc	Tip Length	Qty	Part Number
.030" (0.8 mm)	.041" (1.0 mm)	Spray	1.57" (39.9 mm)	EA	621-0331
.035" (0.9 mm)	.044" (1.1 mm)	Spray	1.57" (39.9 mm)	EA	621-0332
3/64" (1.2 mm)	.060" (1.5 mm)	Spray	1.57" (39.9 mm)	EA	621-0334
1/16" (1.6 mm)	.074" (1.9 mm)	Spray	1.57" (39.9 mm)	EA	621-0335



3/8" Diameter Flex Barrel Tip - Recommended for Flex Barrel*					
Wire Size	Tip ID	Arc	Tip Length	Qty	Part Number
.030" (0.8 mm)	.041" (1 mm)	Spray	1.0" (25.4 mm)	EA	621-0480-25
.035" (0.9 mm)	.044" (1.1 mm)	Spray	1.0" (25.4 mm)	EA	621-0481-25
.045" (1.1mm)	.053" (1.37 mm)	Short	1.0" (25.4 mm)	EA	621-0482-25
3/64" (1.2 mm)	.060" (1.5 mm)	Spray	1.0" (25.4 mm)	EA	621-0483-25

* Used with Flex Barrel cups 621-0465 and 621-0466, on Air Cooled models only

Finned Copper Cups

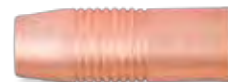

Finned Copper Gas Cups		
Cup Size	Cup I.D.	Part No.
No. 6	3/8" (9.5mm)	621-0248
No. 8	1/2" (12.7mm)	621-0249
No. 10	5/8" (15.8mm)	621-0250*
Heavy Duty Finned Copper Gas Cups		
Cup Size	Cup I.D.	Part No.
10	5/8" (15.8mm)	621-0251
12	3/4" (19.0mm)	621-0252

*Standard - furnished with Air Cooled gun



Air Cooled Cup



Water Cooled Cup Adapter



Water Cooled Cup

Air Cooled Cups for Python Euro Compatible 7 Pin Water Cooled Gun

Cup Size	Cup I.D.	Part No.
No. 6	3/8" (9.5mm)	621-0170
No. 8	1/2" (12.7mm)	621-0159
No. 10	5/8" (15.8mm)	621-0160

To use air cooled gas cups, you must use a cup retaining nut (449-0193) and a water cooled cup adapter (621-0101).

Water Cooled Cups for Python Euro Compatible 7 Pin Water Cooled Gun

Cup Size	Cup I.D.	Part No.
No. 10*	5/8" (15.9mm)	621-0065

*Standard - furnished with gun

Flex Barrel Gas Cups*

Cup Size	Cup I.D.	Part No.
8	1/2" (12.7mm)	621-0465
10	5/8" (15.8mm)	621-0466

*Works with Air Cooled models only



Tip Extender

Tip Extenders and Gun Barrel Liners

Part Number	Description
931-0137	Teflon liner package, 5 pieces
615-0338	Steel wire only, .030 - .1/16" (0.8 - 0.9mm)
621-0424	Python tip extender (Air cooled barrel only)
615-0250	Spiral steel liner for tip extender

Barrel Assemblies

All barrels are rated at 60% duty cycle.

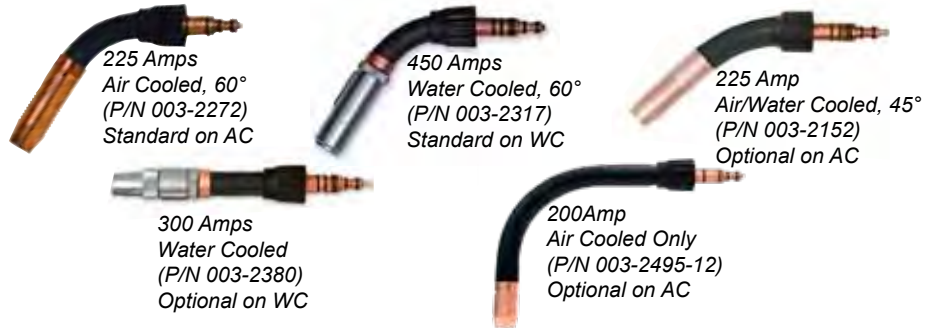

Barrels

Air Cooled

The Python Euro Compatible 7 Pin air cooled gun comes standard with a 60° curved barrel. The barrel assembly locks to the gun body using the patented EZ Lock™ system.

Water Cooled

The Python Euro Compatible 7 Pin water cooled gun comes standard with a 60° curved water cooled barrel assembly.

Optional 6", 12" and 18" Straight and Curved Barrel Assemblies

12" Straight, Air Cooled Barrel Assembly	003-2332
12" Curved, 45° Air Cooled Barrel Assembly.....	003-2333
12" Straight, Water Cooled Barrel Assembly	003-2318
12" Curved, 45° Water Cooled Barrel Assembly.....	003-2319
18" Straight, Air Cooled Barrel Assembly	003-2334
18" Curved, 45° Air Cooled Barrel Assembly.....	003-2335
18" Straight Water Cooled Barrel Assembly	003-2320

Section D

18" Curved, 45° Water Cooled Barrel Assembly.....	003-2321
12" Flex Air Cooled Barrel Assembly, 200 Amps	003-2495-12
18" Flex Air Cooled Barrel Assembly, 200 Amps	003-2495-18
24" Flex Air Cooled Barrel Assembly, 200 Amps	003-2495-24
36" Flex Air Cooled Barrel Assembly, 200 Amps	003-2495-36

Optional 300 Amp Water Cooled Barrel Assemblies

Straight, Water Cooled Barrel Assembly, 300 Amps.....	003-2380
Curved, 45° Water Cooled Barrel Assembly, 300 Amps	003-2381
Curved, 60° Water cooled Barrel Assembly, 300 Amps.....	003-2382

Barrel Removal and Installation

To remove the barrel assembly, loosen the patented EZ Lock™ Taper lock nut until it is clear of the threads. Pull barrel out of the gun body.

To replace a barrel assembly, open the drive and idler roll door and seat the barrel assembly until the inlet guide is almost touching the drive and idler roll and the rear face of the barrel is flush with the aluminum body block. Take care not to damage the "O" rings when inserting into the body. Tighten taper lock nut assembly firmly so that barrel cannot rotate.

Barrel Rotation

To rotate a barrel assembly, loosen the patented EZ Lock™ Taper lock nut assembly no more than 1 turn. Rotate barrel to the position of your choice and retighten taper lock nut assembly firmly so that the barrel cannot rotate.

WARNING: Do not attempt to weld without the barrel being tightly secured in the gun body, or damage to the barrel or body may result.

Maintenance

Periodic Maintenance

Your Cobramatic® System is designed to provide years of reliable service. Maintenance of the gun will normally consist of a general cleaning of the wire guide system, including barrels, drive rolls, and conduits at regular intervals.

Remove spatter build-up from inside of nozzles with a hardwood stick.

The only parts on the Cobramatic® system that are subject to normal wear are the conduit, contact tips, gas cups, front body liners, wire guides, drive and idler rolls. A supply of these parts should be maintained on hand.

The number of units in operation and the importance of minimal "down time" will determine to what extent spare parts should be stocked on hand. See the "Recommended Spare Parts List" for the most commonly replaced parts.

If repairs do become necessary, qualified shop maintenance personnel can easily replace any part.

Maintenance Tools

Tool	Part Number
Contact Tip Removal Tool	931-0044
Drive Roll Removal Tool	931-0100

Recommended Spare Parts List

Qty.	Part No.	Description
1	615-0620-15	Conduit - 15 ft
1	615-0620-25	Conduit - 25 ft
1	615-0620-35	Conduit - 35 ft
1	615-0620-50	Conduit - 50 ft
1	437-0253	Drive Roll Door
2	005-0694	Trigger Assy. Kit
2	005-0695	Potentiometer Kit
1	005-0699	Handle Kit
2	005-0701	Micro-Switch Kit
10	511-0101	Drive Roll
5	005-0686	Idler Roll Kit



DRIVE ROLL REMOVAL TOOL
931-0100



IDLER ROLL
005-0686



MICRO SWITCH ASSEMBLY
005-0701



KNURLED DRIVE ROLL
511-0101

Troubleshooting Guide

Regardless of which gun or feeder used, all MK Products' push-pull guns operate on the same principle. The slave motor in the feeder runs at a fast, constant speed, but has very low torque. It is always trying to feed more wire than the gun motor wants, and when the motor gets all it wants, it slows the slave motor, preventing a bird's nest. Because of the low torque produced by the slave motor, a brake system is used to prevent wire overrun rather than tension. The drag adjustment in the feeder is used simply to keep the wire slightly taut, so it will not pull off the spool while feeding wire.

The high torque 24VDC gun motor is controlled by a solid state speed control located in the feeder, and a pot located in the gun. The gun motor, potentiometer, and micro switch are connected to the cabinet/control box via a control cable and Amphenol connector. If this cable becomes damaged, a variety of symptoms can occur, depending on which wire(s) break. To test, check each wire for continuity and shorts.

Remember, the micro switch in the gun activates both the slave motor and gun motor circuits in the cabinet. Therefore, if the slave motor and brake solenoid operate, but the gun does not, look more toward the gun motor's 24V circuits, speed control, control cable, or the gun motor. If nothing operates, look more toward the slave motor's input, micro switch leads, or micro switch.

Testing The Gun

Reference the "W" clocked gun wiring diagram on the Python Euro Compatible 7 Pin electrical diagram for information about pin-outs and locations.

Motor Check

Remove the gun connector from the cabinet.

Using the gun Amphenol connector, check the resistance across pins "A" and "B" (motor leads).

If an open circuit (more than **K ohms**) or short exist (less than **2 ohms**) exists, check the motor leads and motor independently.

Testing the Potentiometer - "W" Clocked

Using the gun amphenol connector, check the resistance across pin "D" (wiper) and pin "C". The resistance should vary from **0 - 5K ohms** as the potentiometer is turned.

Check the resistance across pin "D" (wiper) and pin "G". The resistance should vary from **5K - 0 ohms** as the potentiometer is turned.

Testing the Micro Switch

Using the gun amphenol connector, check for continuity across pins "E" and "F" when the trigger is pressed.

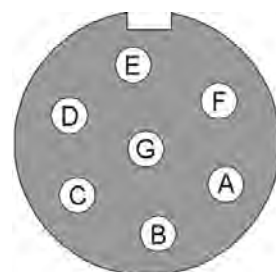

"W" Clocked
Amphenol Connector
Viewed from front of connector

Section E

Troubleshooting

Trouble	Cause	Remedy
No wire feed at gun, feeder not operating, i.e. no slave motor or brake solenoid.	115/42 VAC Control fuse in feeder/Control box blown.	Replace fuse.
	Micro-switch defective/not being activated.	Replace switch. Check switch for operation.
	Broken electrical cable.	Check micro-switch wires for continuity.
No wire feed at gun, feeder operating properly.	24 VAC Control fuse in feeder/Control box blown.	Check motor leads for shorts; then replace fuse.
	Bad potentiometer.	Check potentiometer with meter.
	Broken Electrical Cable.	Check motor and potentiometer wires for continuity.
	Bad Speed control/PCB	See specific cabinet/control box owners manual for speed control operation.
Wire feeds, but welding wire is not energized.	Loose or no cable connections.	Check all power connections.
	Contactors control cable loose or in wrong position.	Check power supply owners manual for location and type of contactor signal required.
	Welding power source.	Check power source.
Wire feeds erratically.	Dirty or worn conduit.	Blow out or replace conduit.
	Wrong size contact tip.	See Contact tip table.
	Idler roll stuck.	Check for lock washer under idler roll, or replace if damaged.
Wire feeds one speed only.	Bad potentiometer.	Check with meter.
	Broken electrical cable.	Check potentiometer wires for continuity or short.
	Bad speed control.	See specific cabinet/control owners manual for speed control operation.
Wire walks out of drive rolls.	Idler roll upside-down.	Place groove in idler roll toward top.
	Rear wire guide missing.	Replace wire guide.

Appendices

Diagrams / Parts List

Exploded View	12
Bill of Material	13
Front Body Assembly	14
Rear Body Assembly, Air Cooled	15
Rear Body Assembly, Water Cooled.....	16
Barrel Assembly, Air Cooled	17
Barrel Assembly, Water Cooled	18
Cup Insulator and O-Ring Maintenance	19
Lead Assembly, Air Cooled.....	20
Lead Assembly, Water Cooled.....	22
Lead Assembly Spiral Wrap Installation	24
Power Manifold, Air Cooled	27
Power Manifold, Water Cooled	28
Electrical	29

Python Euro Compatible 7 Pin Head Assembly

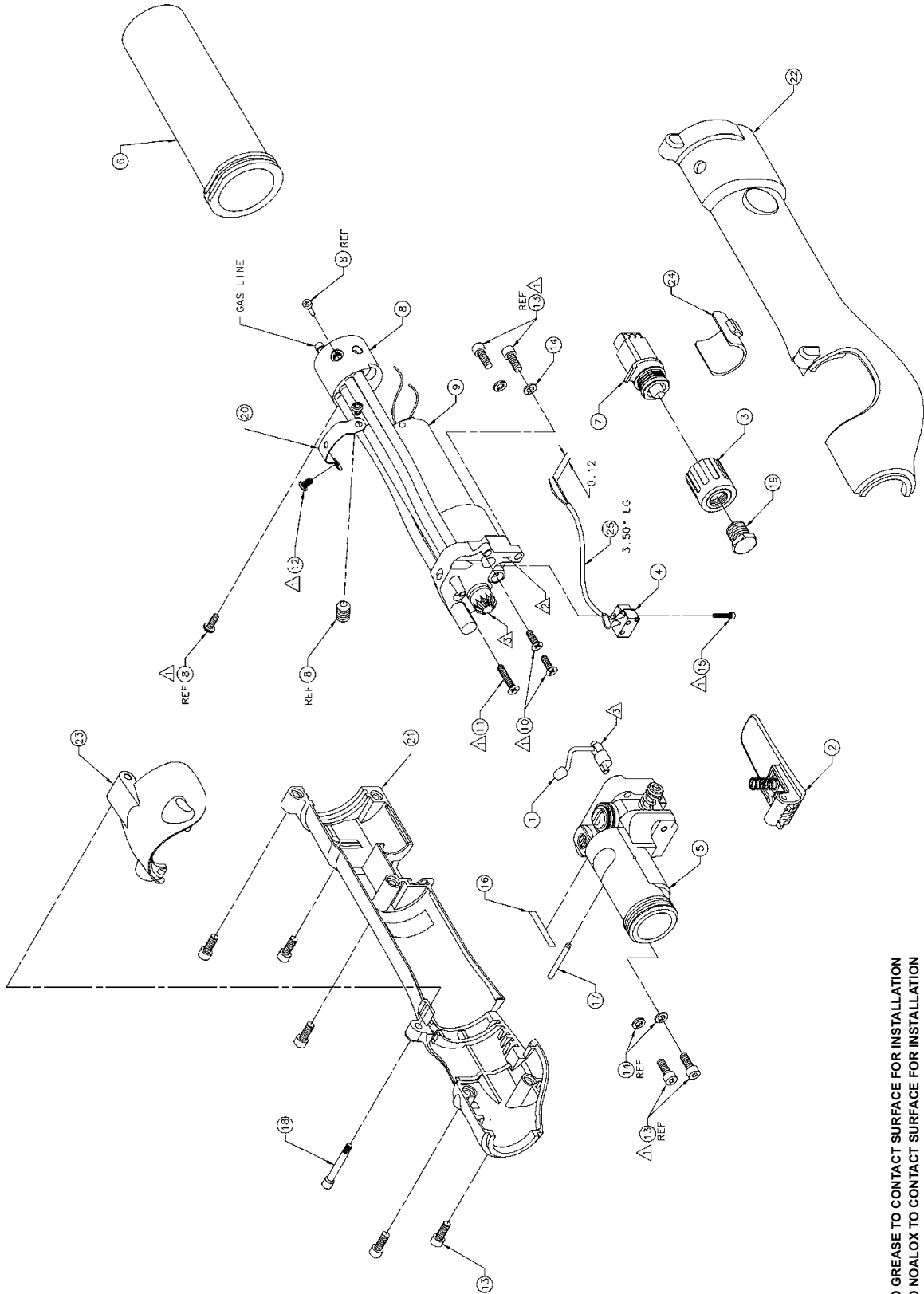

APPLY COMPOUND GREASE TO CONTACT SURFACE FOR INSTALLATION
 APPLY COMPOUND NOALOX TO CONTACT SURFACE FOR INSTALLATION
 APPLY THREAD LOCKING COMPOUND TO CONTACT SURFACE FOR INSTALLATION

Python Euro Compatible 7 Pin Head Assembly

No.	Qty.	Part No.	Description	No.	Qty.	Part No.	Description
1	1	002-0629	Assy Cam Idler Arm	12	2	320-0101	Scr Button 4-40 x 3/16 SST
2	1	005-0694	Trigger Kit	13	9	338-0022	Scr SHC 6-32 x 3/8 SST
3	1	003-2125	Assy Knob Pot	14	4	333-0260	Wshr Spr LK #6 SST
4	1	005-0701	Micro Swx Kit	15	1	338-0153	Scr SHC 1-72 x 3/8 SST
5	1	003-2271	Front Body Assy, A/C	16	1	405-0706	Label
	1	003-2108	Front Body Assy, W/C	17	1	421-0018	Pin Dowel 3/32 x 7/8
6	1	003-2153	Assy Boot Torch	18	1	431-1622	Scr Shoulder 1/8 x 4-40
7	1	005-0695	Assy Speed Control Pot Kit	19	1	431-1637	Screw Hex 3/8-20 x 3/8
8	1	003-2289	Rear Body Assy, A/C	20	1	435-1585	Strap Motor Python
	1	003-2287	Rear Body Assy, W/C	21	1	005-0699	Handle Kit: Includes line items 13, 18, and 23
9	1	211-0077	Motor 24VDC, Standard	22			
	1	211-0080	Motor 24VDC, Hi-Speed (optional)	23	1	437-0253	Door Molded Python
10	2	319-0254	Scr FH Phil 82 4-40 x 3/8 SST	24	1	437-0268	Cover Knob Python
11	1	319-0258	Scr FH Phil 82 4-40 5/8 SST	25	0.30 ft.	737-0048	Tube, Insulation 9AWG, Clear

**Python Euro Compatible 7 Pin
Front Body Assembly
P/N 003-2271 (Air Cooled)
P/N 003-2108 (Water Cooled)**

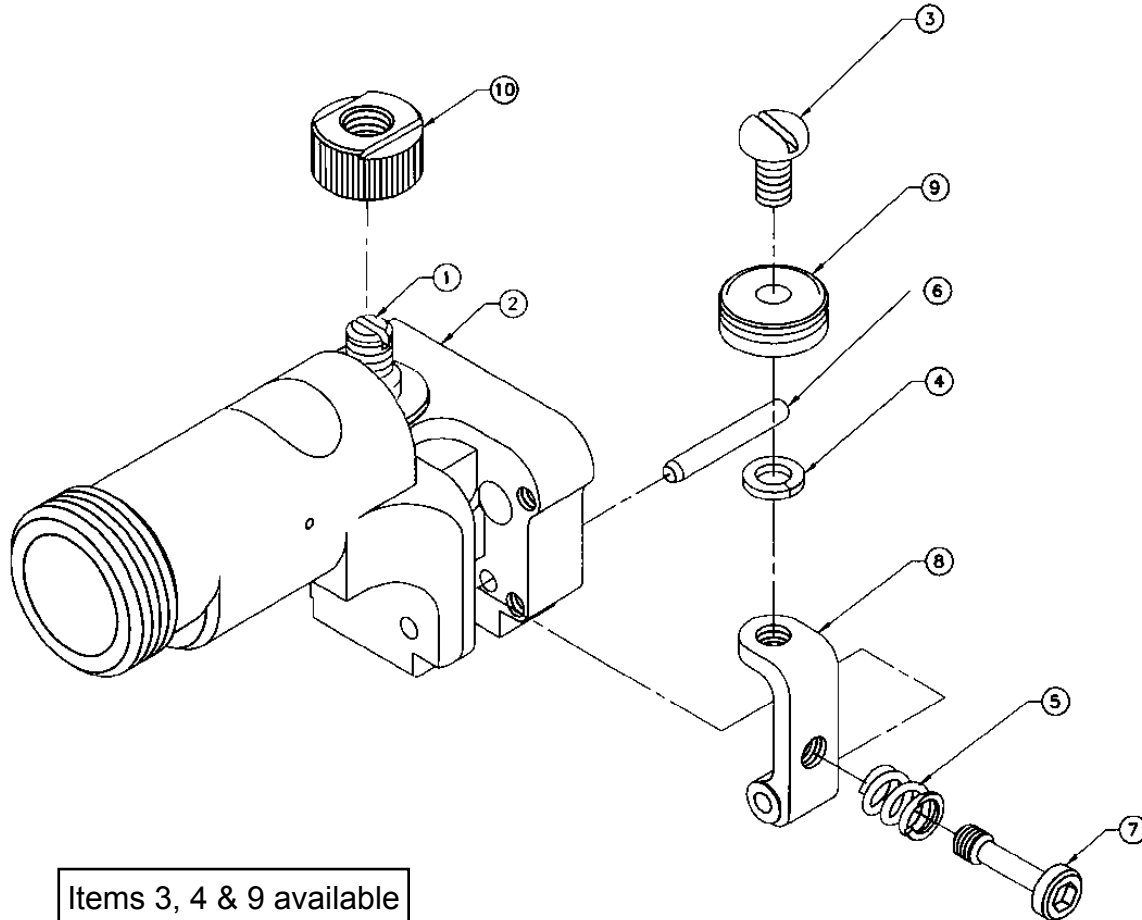

Items 3, 4 & 9 available
as package kit:
P/N 005-0686

Front Body Assembly			
No.	Qty.	Part No.	Description
1	-	-	Not available separately
2	-	-	
3*	1	325-0206	10-24 x 3/8 PH Screw
4*	1	333-0082	# 10 Lock Washer
5	1	419-0092	0.29 x 0.047 x 0.32 Comp. Spring
6	1	421-0525	1/8 x 7/8 SST Dowel Pin
7	1	431-1663	Idler Adjusting Screw
8	1	431-1598	Idler Arm
9*	1	511-0001	Idler Wire Feed Assembly
10	1	511-0101	Drive roll

* Items 3, 4 & 9 available as package kit: **Part number 005-0686**

Python Euro Compatible 7 Pin Rear Body Assembly, Air Cooled 003-2289

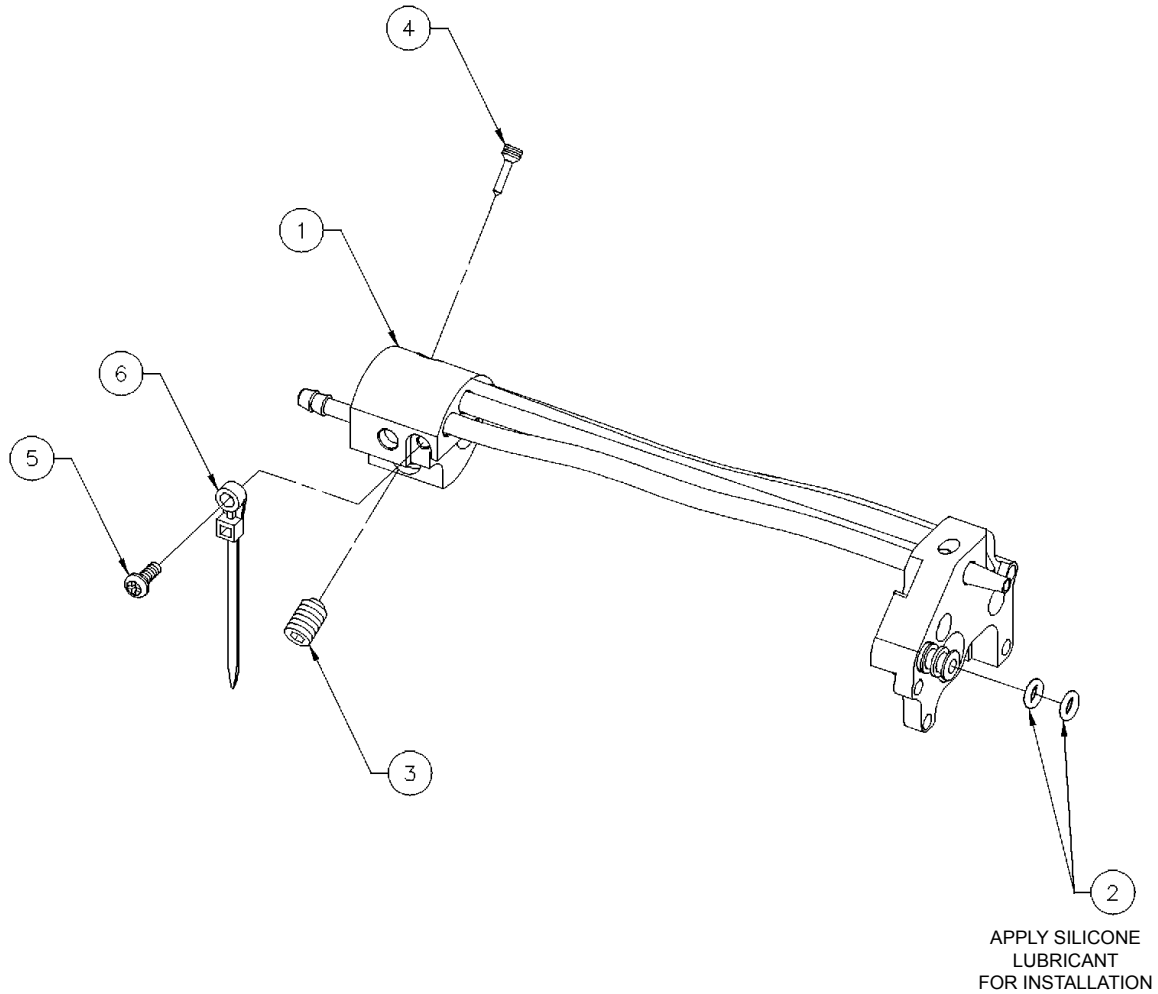

Air Cooled Rear Body Assembly			
No.	Qty.	Part No.	Description
1	-	-	Not available separately
2	2	303-0096	O-Ring .145 ID x .07 W
3	1	321-1082	Set Screw Flat 1/4-20 5/16 SST
4	1	321-1104	Set Screw Mod Conduit
5	1	336-0020	Scr PH Phil 4-40 x 5/16 SST
6	1	411-0243	Tie Wrap Scr 4

Python Euro Compatible 7 Pin Rear Assembly, Water Cooled 003-2287

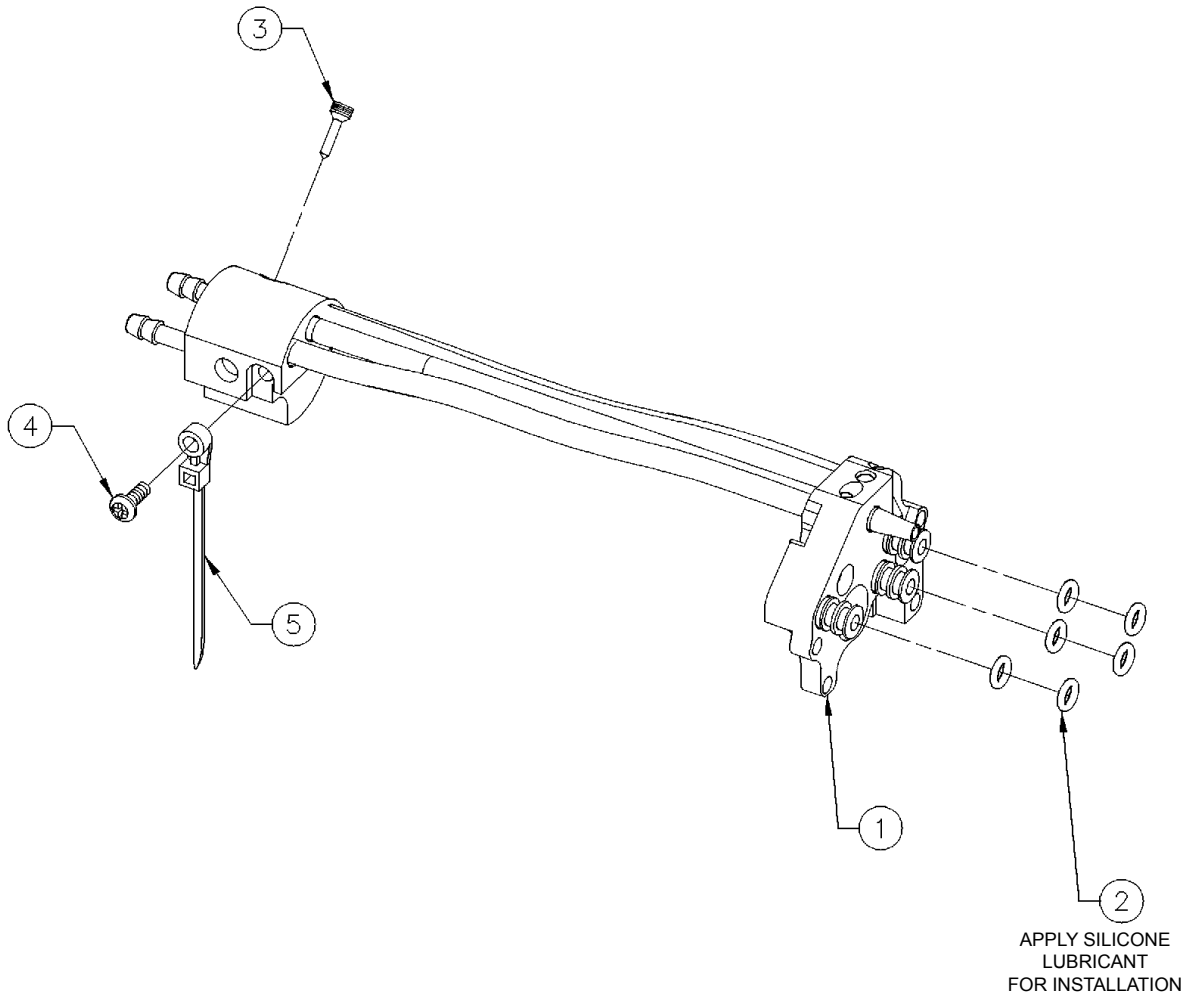

Rear Body Assembly - Water Cooled			
No.	Qty.	Part No.	Description
1	-	-	Not available separately
2	6	303-0096	O-Ring .145 ID x .07 W
3	1	321-1104	Set Screw Mod Conduit
4	1	336-0020	Scr PH PHil 4-40 x 5/16 SST
5	1	411-0243	Tie Wrap Scr 4

Python Euro Compatible 7 Pin Barrel Assembly

Air Cooled

P/N 003-2272

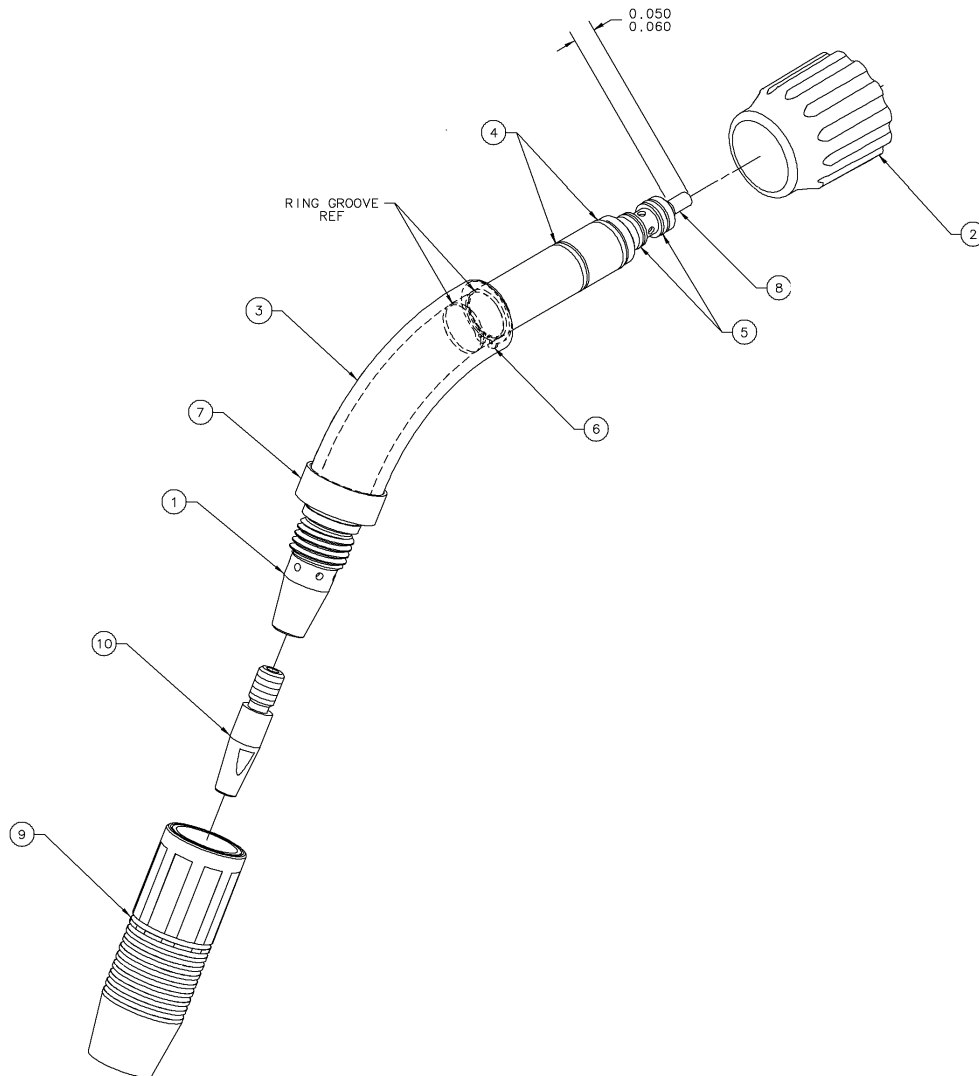

*Apply silicone lubricant to items 4 and 5 before installing.

Air Cooled 60° Curved Barrel Assembly			
No.	Qty.	Part Number	Description
1	-	-	Not available separately
2	1	005-0696	Taper Lock Kit
3	1	261-0143	Insulator Barrel
4*	2	303-0010	O-Ring .489 ID x .07 W
5*	2	303-0094	O-Ring .301 ID x .07 W
6	1	313-0091	Retaining Ring 5/8 Shaft
7	1	431-1774	Cup Insulator Barrel
8	0.63 ft	615-0178	Liner Tef 0.084 ID x 0.174 OD
9	1	621-0250	Assy Cup Copper Finned #10
10	1	621-0393	Tip HD Spray .060

Python Euro Compatible 7 Pin Barrel Assembly Water Cooled P/N 003-2317

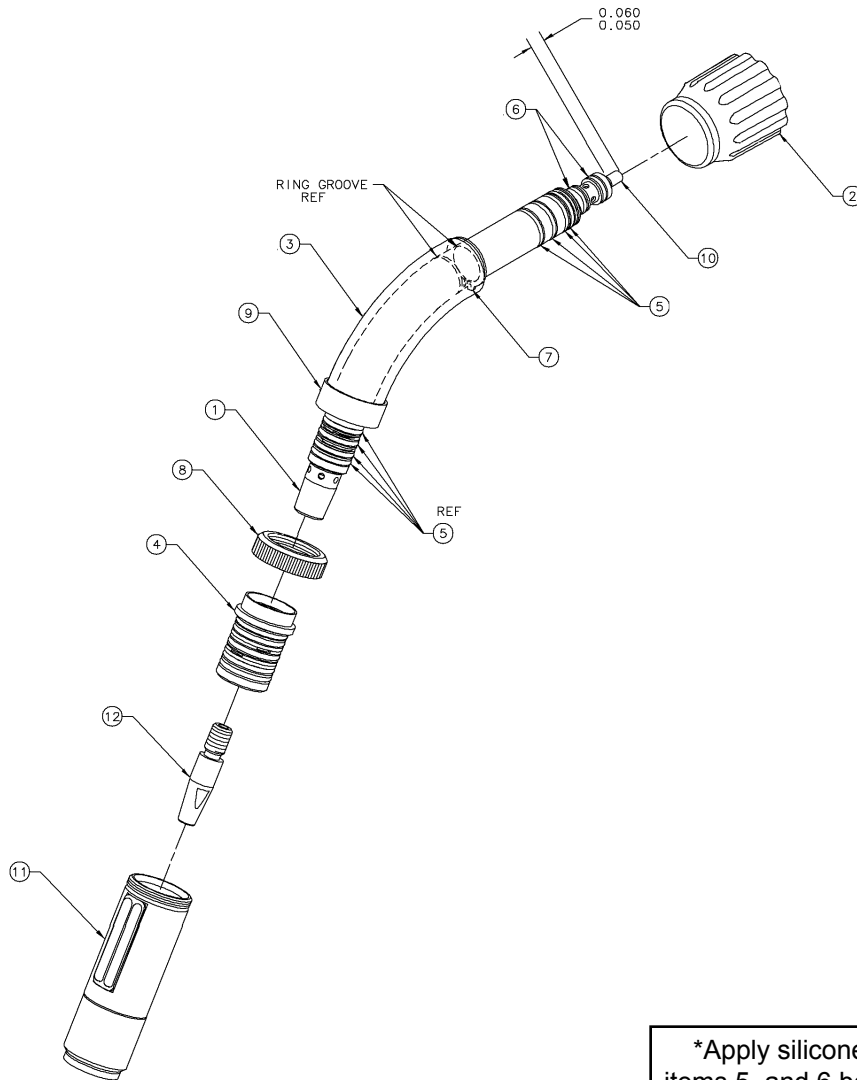

*Apply silicone lubricant to items 5, and 6 before installing.

Water Cooled 60° Curved Barrel Assembly			
No.	Qty.	Part No.	Description
1	-	-	Not available separately
2	1	005-0696	Taper Lock Kit
3	1	261-0141	Insulator Barrel
4	1	261-0381	Insulator Cup with five O-Rings
5*	8	303-0010	O-Ring .489 ID x .07 W
6*	2	303-0094	O-Ring .301 ID x .07 W
7	1	313-0091	Retaining Ring 5/8 Shaft
8	1	431-0977	Retaining Nut
9	1	431-1774	Cup Insulator Barrel
10	0.70 ft.	615-0178	Liner Tef 0.084 ID x 0.174 OD
11	1	621-0065	Cup #10 Assy
12	1	621-0393	Tip HD Spray .060

CUP INSULATOR AND O-RING MAINTENANCE

CAUTION: Power-off the coolant pump before disassembling water-cooled barrels.

1. Unscrew Retaining Nut and slide back on barrel.
2. Using a firm pull and twist action, the Water-Cooled Gas Cup or Air-Cooled Gas Cup Assembly can be removed from the Cup Insulator.
3. Inspect the Cup Insulator and o-rings (included with Insulator) for wear and proper lubrication. It is considered good practice to replace all o-rings at the same time.
4. To remove the Cup Insulator, it must be unscrewed and pulled from the barrel. Use a rag or towel (due to o-ring lubrication) and wrap it around the Cup Insulator.

Unscrew and pull when completed unthreaded from barrel. Be sure the Insulator is fully unscrewed from the threads. Pulling the Insulator over barrel threads will damage the threads on the Insulator.

Inspect o-rings on barrel for wear and lubrication. It is considered good practice to replace all o-rings at the same time.

5. To install the Cup Insulator, it must be pushed all the way onto the barrel then screwed onto the threads. If necessary, place small amount of o-ring lubricant on the inside diameter of the Cup Insulator, this will help it slide onto the barrel.

Push the Insulator onto the barrel until it bottoms out, screw onto barrel threads.

The Insulator **MUST** be all the way onto the barrel to avoid assure proper coolant passage and from blocking the gas outlet orifices.

6. Push Water-Cooled Gas Cup or Chrome Nut, Cup Adapter and Gas Cup Assembly onto Cup Insulator. Slide Retaining Nut forward and tighten.

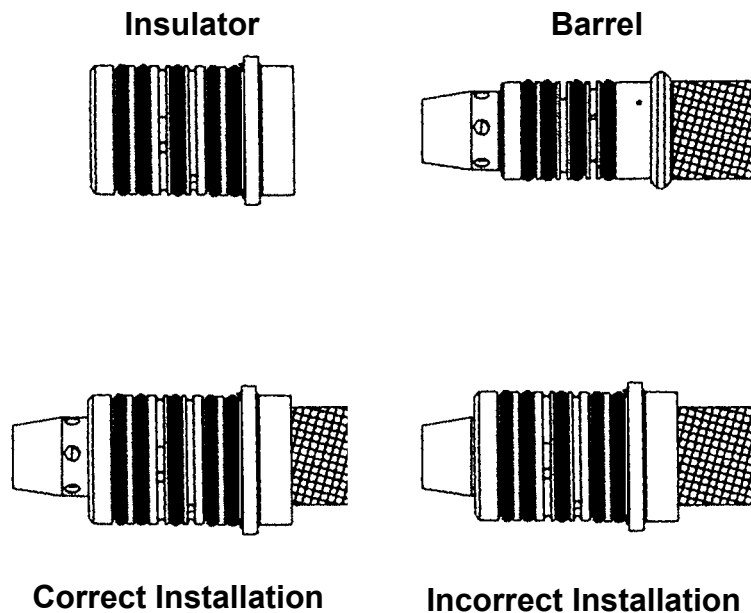

Python Euro Compatible 7 Pin Lead Assembly Air Cooled

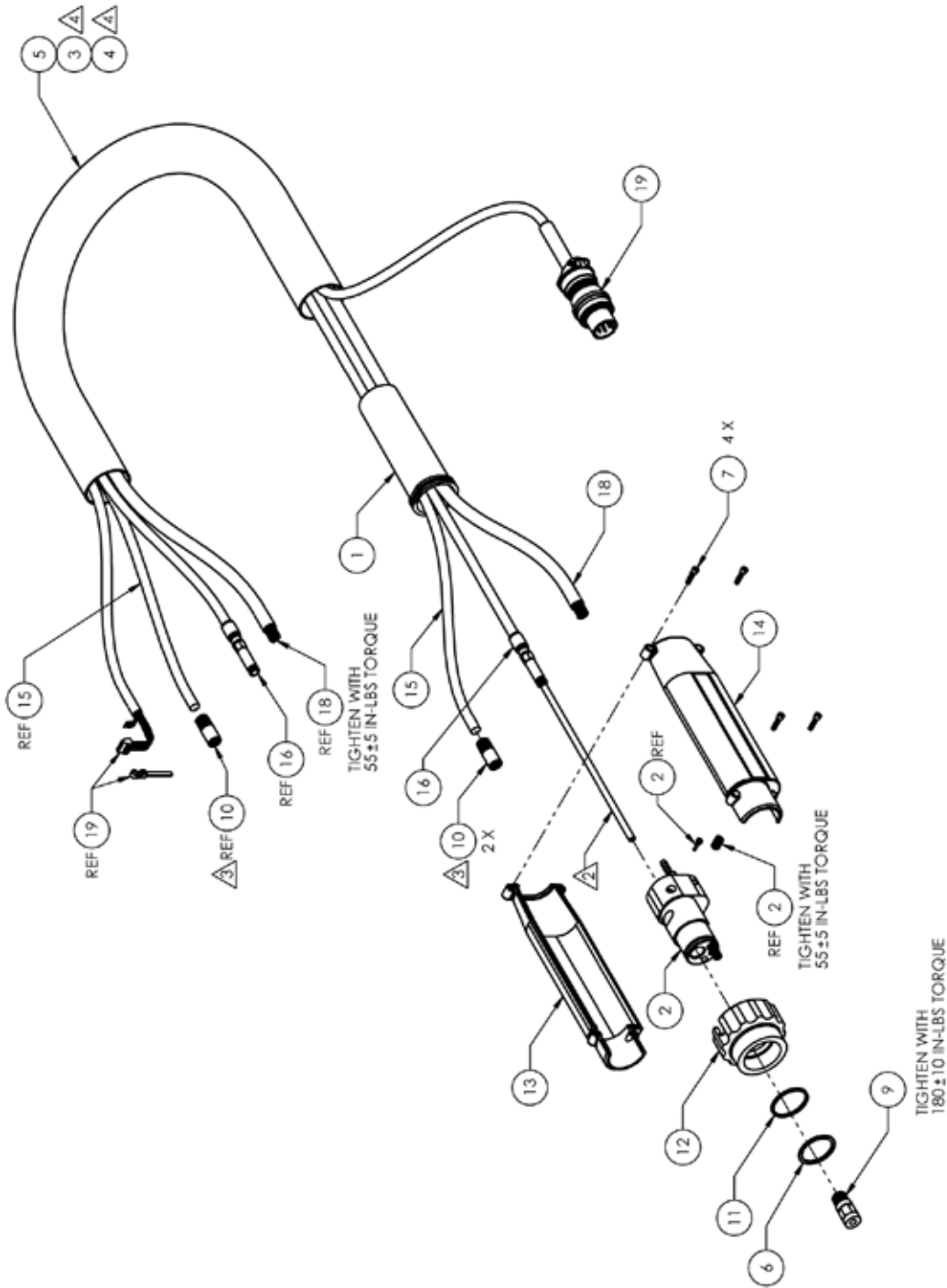

△ SEE PROCEDURE #033-0929

△ APPLY QUICK DRYING HOSE LUBRICANT NEAR BOTH ENDS OF ITEM (15) FOR INSTALLATION OF ITEM (10)

△ TRIM TEFLON LINER AFTER ASSEMBLY. TEFLON LINER TO PROTRUDE 4.44 INCHES BEYOND ITEM (9)

△ ITEM NOT SHOWN FOR CLARITY

Lead Assembly - Air Cooled						
No.	Qty.	Description	15' Part No.	25' Part No.	35' Part No.	50' Part No.
1	1	Assy Boot Torch		003-2153		
2	1	Assy Power Manifold, A/C		003-2373		
3	△ 1	Wrap Spiral Cord, 5.5 in		261-0094		
4	△ 1	Wrap Spiral Cord, 13 in		261-0094-13		
5	1	Snake Skin	931-0110	931-0122	931-0132	931-0123
6	1	Retainer Ring		313-0144		
7	△ 4	Screw SHC 4-40 x 1/2 SST		338-0014		
8	4	Tie Wrap		411-0045		
9	1	Conduit Liner Fitting		431-1788		
10*	2	Hose Retainer, 5/16		431-1898		
11	1	Washer for Euro Connection		431-2052		
12	1	Nut Handle Adapter		437-0265		
13	1	Handle Kit: Includes item 7		005-0385-BLACK		
14	1					
15	1	Assy Gas Hose	552-0241-15	552-0241-25	552-0241-35	552-0241-50
16	1	Conduit Tef Tube	615-0620-15	615-0620-25	615-0620-35	615-0620-50
17	-	-		-----		
18**	1	Assy Power Cable Global	843-0640-15	843-0640-25	843-0640-35	843-0640-50
	1	Ultra Flex Power Cable (optional)	843-0715-15	843-0715-25	843-0715-35	843-0715-50
19	1	Assy Controller Cable	005-0690	005-0691	005-0740	005-0692

* Hose Retainer is re-usable and can be removed and re-installed as needed

** Power Cable includes copper wrap P/N 701-0053-1

Python Euro Compatible 7 Pin Lead Assembly Water Cooled

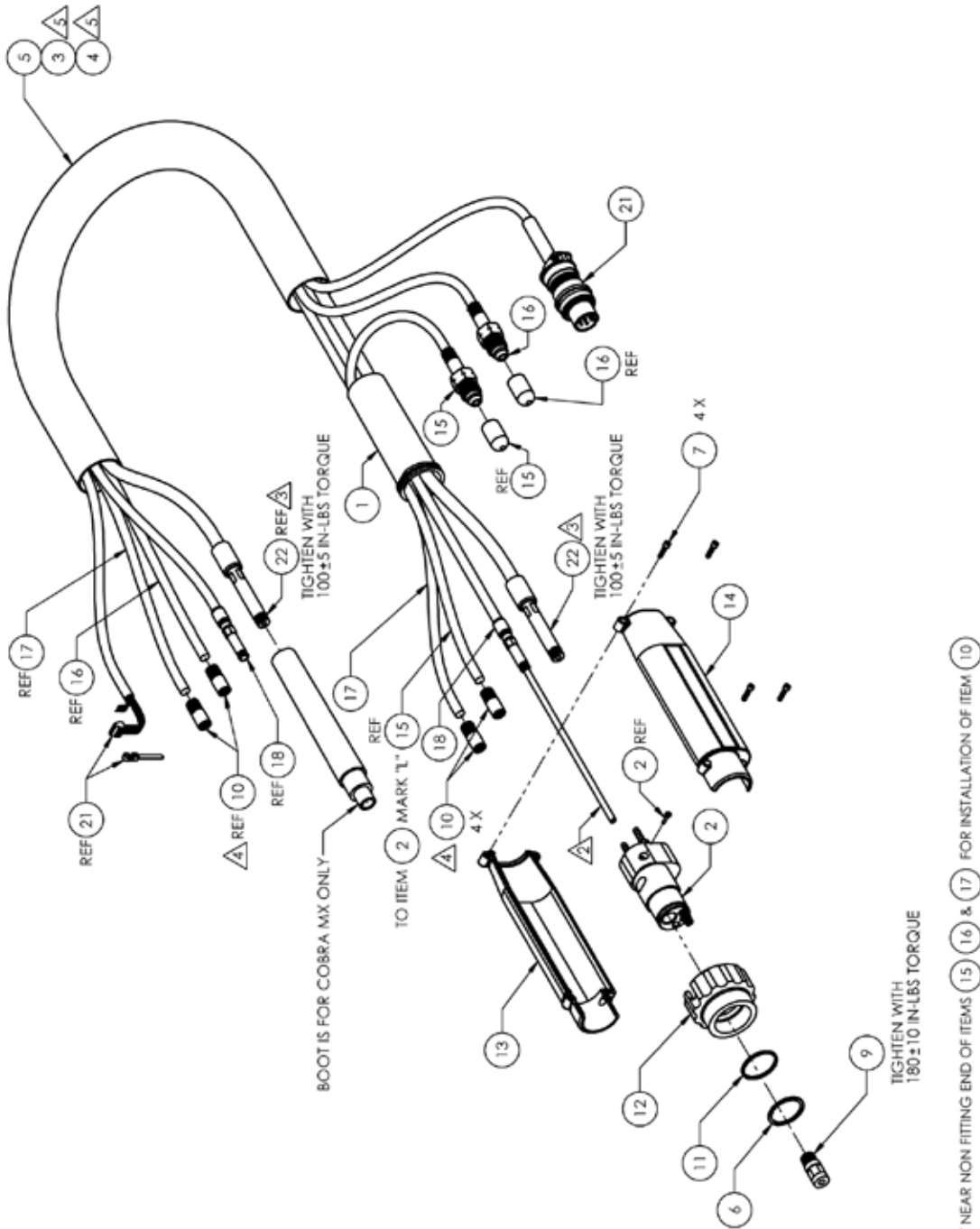

- ▲ SEE PROCEDURE #033-0929.
- ▲ APPLY QUICK DRYING HOSE LUBRICANT NEAR NON FITTING END OF ITEMS (15) (16) & (17) FOR INSTALLATION OF ITEM (10)
- ▲ APPLY COMPOUND JOINT NOALOX TO THE EXTERNAL THREADS OF ITEM (22)
- ▲ TRIM TEFLON LINER AFTER ASSEMBLY. TEFLON LINER TO PROTRUDE 3.30 INCHES BEYOND ITEM (9)
- ▲ ITEM NOT SHOWN FOR CLARITY

Lead Assembly - Water Cooled						
No.	Qty.	Description	15' Part No.	25' Part No.	35' Part No.	50' Part No.
1	1	Assy Boot Torch		003-2153		
2	1	Assy Power Manifold, W/C		003-2378		
3	△1	Wrap Spiral Cord, 5.5 in		261-0094		
4	△1	Wrap Spiral Cord, 13 in		261-0094-13		
5	1	Snake Skin	931-0110	931-0122	931-0132	931-0123
6	△1	Retainer Ring		313-0144		
7	4	Screw SHC 4-40 x 1/2 SST		338-0014		
8	4	Tie Wrap		411-0045		
9	1	Conduit Liner Fitting		431-1788		
10*	4	Hose Retainer, 5/16		431-1898		
11	1	Washer for Euro Connection		431-2052		
12	1	Nut Handle Adapter		437-0265		
13	1	Handle Kit: Includes item 7		005-0385-BLACK		
14	1					
15	1	Assy Hose Water RED		552-0209		
16	1	Assy Hose Water, BLUE	552-0239-15	552-0239-25	552-0239-35	552-0239-50
17	1	Assy Gas Hose	552-0241-15	552-0241-25	552-0241-35	552-0241-50
18	1	Conduit Tef Tube	615-0620-15	615-0620-25	615-0620-35	615-0620-50
19	-	-		----		
20	-	-		----		
21	1	Assy Controller Cable	005-0690	005-0691	005-0740	005-0692
22	1	Assy Power Cable/Water Euro	843-0680-15	843-0680-25	843-0680-35	843-0680-50

* Hose Retainer is re-usable and can be removed and re-installed as needed

Python Euro Compatible 7 Pin Lead Assembly Spiral Wrap Installation 033-0929

Gun End, Air Cooled

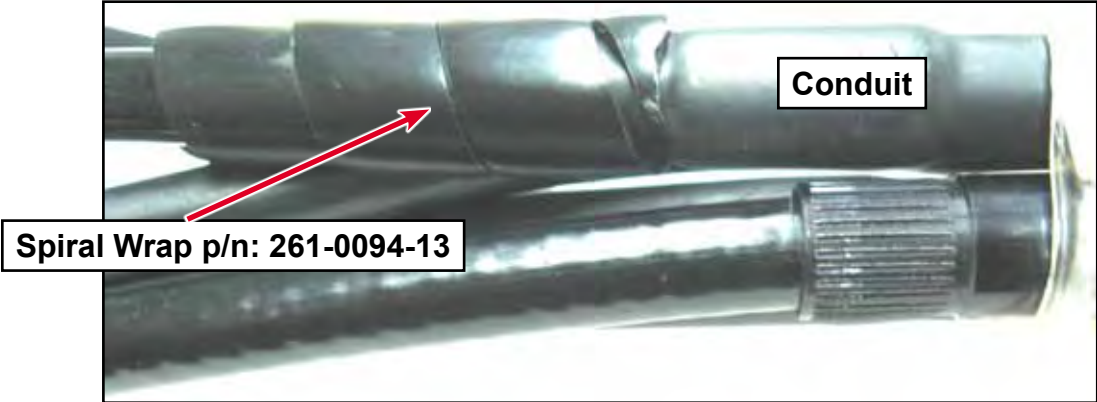

Python Euro Compatible 7 Pin Lead Assembly Spiral Wrap Installation 033-0929

Gun End, Water Cooled

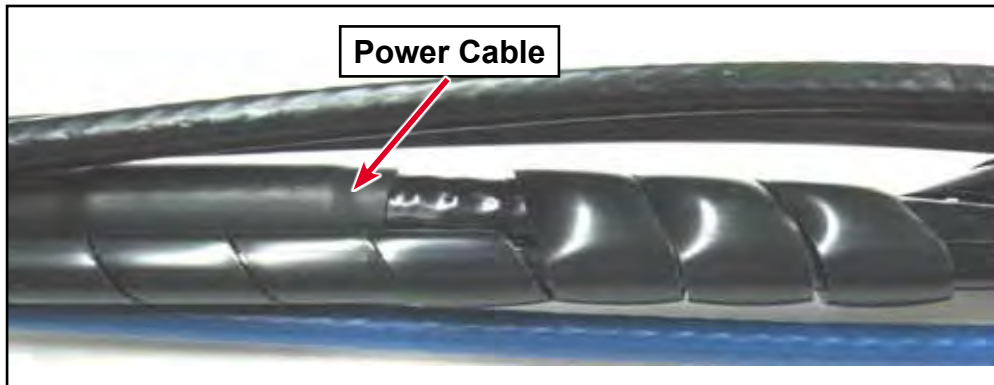
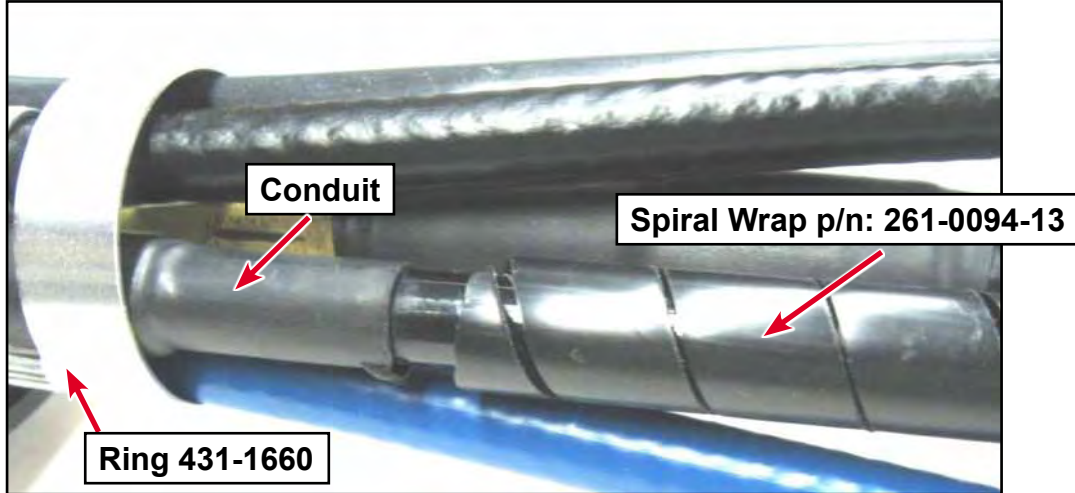

Python Euro Compatible 7 Pin Lead Assembly Spiral Wrap Installation 033-0929

Cabinet End, Air and Water Cooled



Spiral Wrap p/n: 261-0094



Python Euro Compatible 7 Pin Power Manifold Assembly, Air Cooled P/N 003-2373

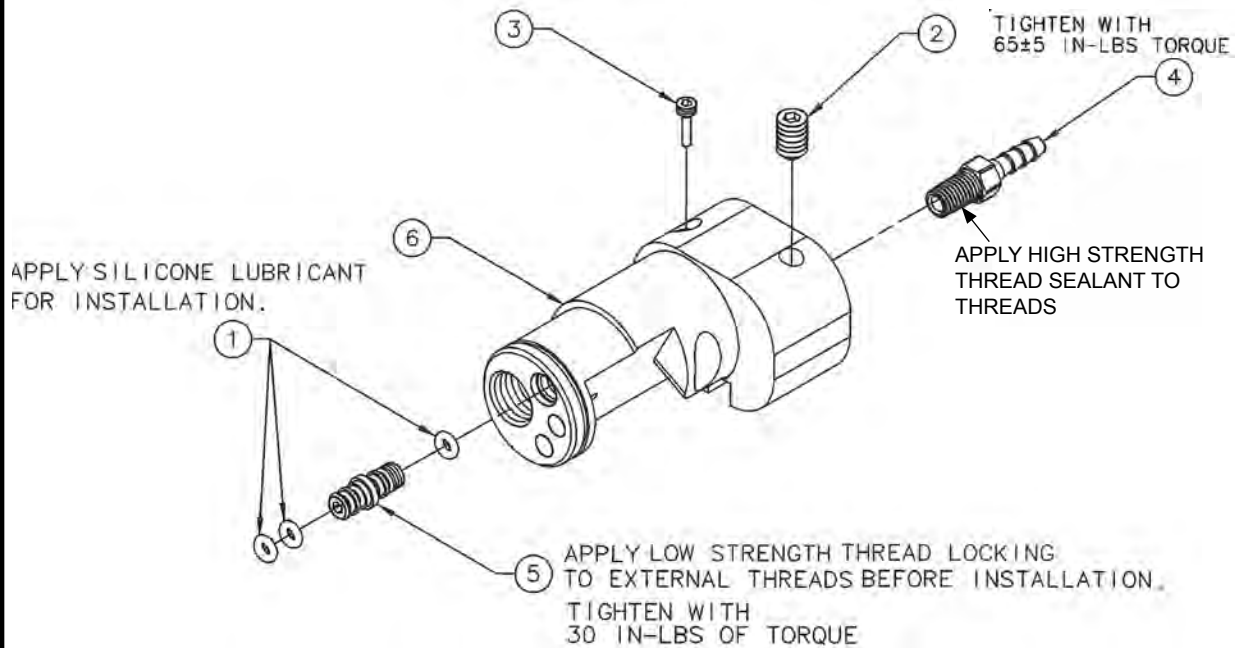

Air Cooled Power Manifold Assembly			
No.	Qty.	Part No.	Description
1	3	303-0097	O-Ring Buna-N .101 ID x .07W
2	1	321-1082	Set Screw Flat 1/4 - 20 x 3/8 SST
3	1	321-1104	Set Screw Conduit
4	1	431-1905	Fitting 1/8 ID x 1/16 - 27 NPT
5	1	431-1948	Connector Thread
6	-	-	Not available separately

Python Euro Compatible 7 Pin Power Manifold Assembly, Water Cooled P/N 003-2378

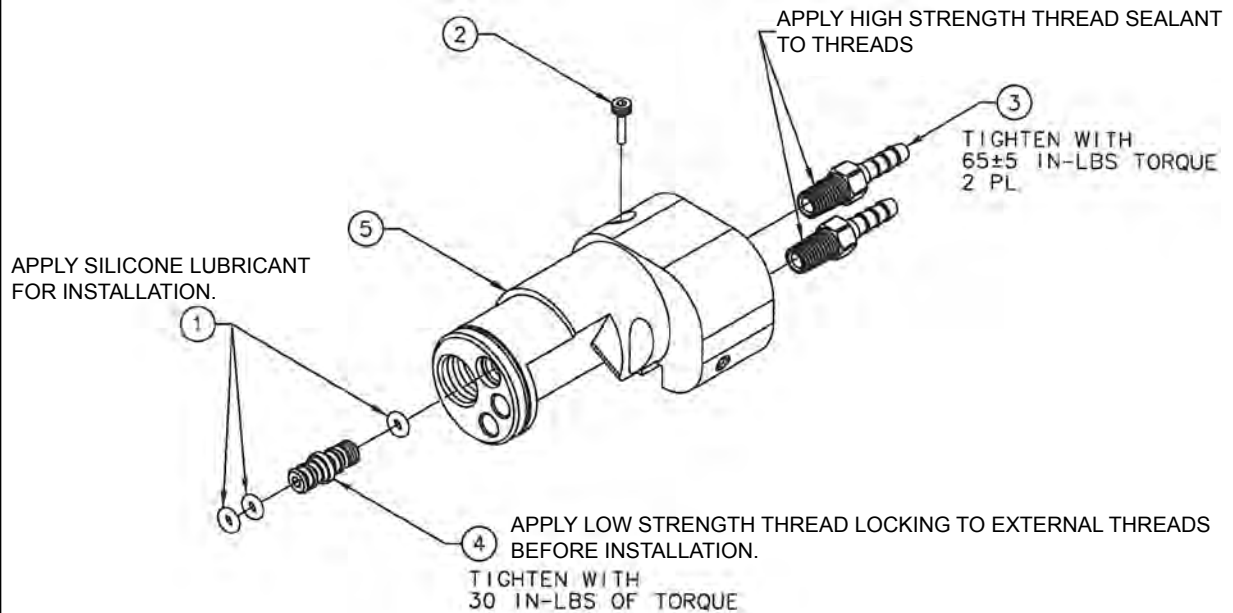

Water Cooled Power Manifold Assembly			
No.	Qty.	Part No.	Description
1	1	303-0097	O-Ring Buna-N .101 ID x .07W
2	1	321-1104	Set Screw Conduit
3	2	431-1905	Fitting 1/8 ID x 1/16 - 27 NPT
4	1	431-1948	Connector Thread
5	-	-	Not available separately

Python Euro Compatible 7 Pin Electrical

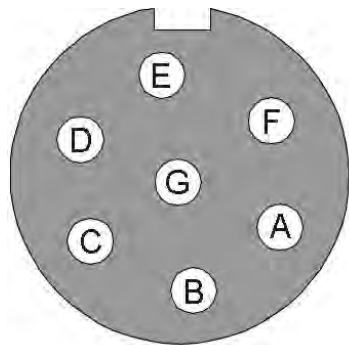

"W" Clocked
Amphenol Connector
Viewed from front of connector

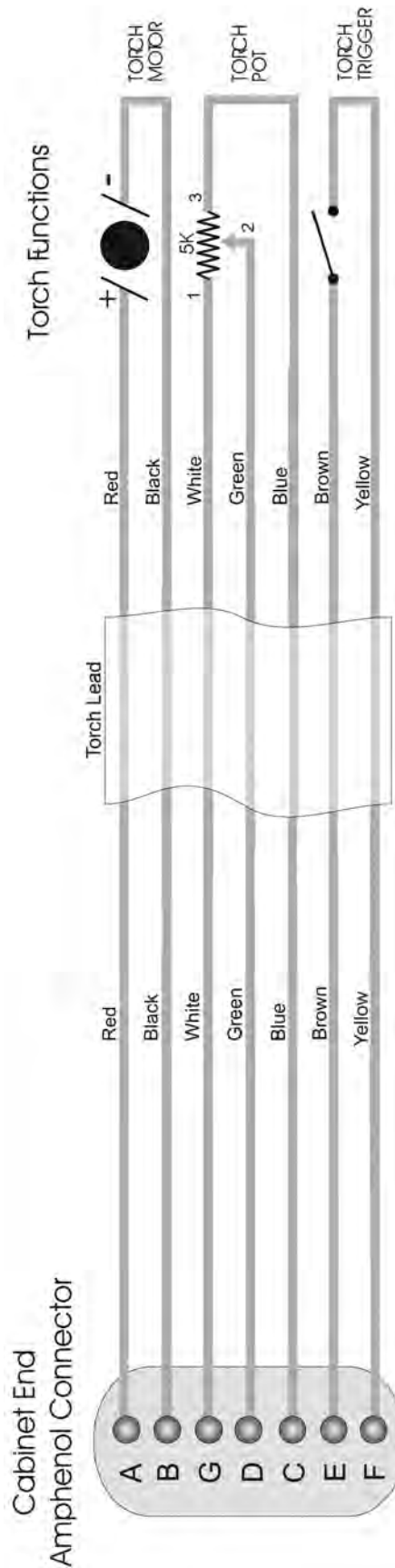

			
WARNING	<ul style="list-style-type: none"> ● Do not touch electrically live parts or electrode with skin or wet clothing. ● Insulate yourself from work and ground. 	<ul style="list-style-type: none"> ● Keep flammable materials away. 	<ul style="list-style-type: none"> ● Wear eye, ear and body protection.
Spanish AVISO DE PRECAUCION	<ul style="list-style-type: none"> ● No toque las partes o los electrodos bajo carga con la piel o ropa mojada. ● Aísiense del trabajo y de la tierra. 	<ul style="list-style-type: none"> ● Mantenga el material combustible fuera del área de trabajo. 	<ul style="list-style-type: none"> ● Protéjase los ojos, los oídos y el cuerpo.
French ATTENTION	<ul style="list-style-type: none"> ● Ne laissez ni la peau ni des vêtements mouillés entrer en contact avec des pièces sous tension. ● Isolez-vous du travail et de la terre. 	<ul style="list-style-type: none"> ● Gardez à l'écart de tout matériel inflammable. 	<ul style="list-style-type: none"> ● Protégez vos yeux, vos oreilles et votre corps.
German WARNUNG	<ul style="list-style-type: none"> ● Berühren Sie keine stromführenden Teile oder Elektroden mit Ihrem Körper oder feuchter Kleidung! ● Isolieren Sie sich von den Elektroden und dem Erdboden! 	<ul style="list-style-type: none"> ● Entfernen Sie brennbares Material! 	<ul style="list-style-type: none"> ● Tragen Sie Augen-, Ohren- und Körperschutz!
Portuguese ATENÇÃO	<ul style="list-style-type: none"> ● Não toque partes elétricas e electrodos com a pele ou roupa molhada. ● Isole-se da peça e terra. 	<ul style="list-style-type: none"> ● Mantenha inflamáveis bem guardados. 	<ul style="list-style-type: none"> ● Use proteção para a vista, ouvido e corpo.
Japanese 注意事項	<ul style="list-style-type: none"> ● 通電中の電気部品、又は溶材にヒフやぬれた布で触れないこと。 ● 施工物やアースから身体が絶縁されている様にして下さい。 	<ul style="list-style-type: none"> ● 燃えやすいものの側での溶接作業は絶対にしてはなりません。 	<ul style="list-style-type: none"> ● 目、耳及び身体に保護具をして下さい。
Chinese 警告	<ul style="list-style-type: none"> ● 皮肤或湿衣物切勿接觸帶電部件及鉗條。 ● 使你自已與地面和工件絕緣。 	<ul style="list-style-type: none"> ● 把一切易燃物品移離工作場所。 	<ul style="list-style-type: none"> ● 佩戴眼、耳及身體勞動保護用具。
Korean 위험	<ul style="list-style-type: none"> ● 진도체나 용접봉을 젖은 환경 또는 피부로 절대 접촉치 마십시오. ● 모재와 접지를 접촉치 마십시오. 	<ul style="list-style-type: none"> ● 인화성 물질을 접근 시키지 마십시오. 	<ul style="list-style-type: none"> ● 눈, 귀와 몸에 보호장구를 착용하십시오.
Arabic تحذير	<ul style="list-style-type: none"> ● لا تلمس الاجزاء التي يسري فيها التيار الكهربائي أو الأقطاب بجلد الجسم أو بالمعاطس المبللة بالماء. ● ضع عازلا على جسمك خلال العمل. 	<ul style="list-style-type: none"> ● ضع المواد القابلة للاشتعال في مكان بعيد. 	<ul style="list-style-type: none"> ● ضع أدوات وملابس واقية على عينيك وأذنيك وجسمك.

READ AND UNDERSTAND THE MANUFACTURER'S INSTRUCTION FOR THIS EQUIPMENT AND THE CONSUMABLES TO BE USED AND FOLLOW YOUR EMPLOYER'S SAFETY PRACTICES.

SE RECOMIENDA LEER Y ENTENDER LAS INSTRUCCIONES DEL FABRICANTE PARA EL USO DE ESTE EQUIPO Y LOS CONSUMIBLES QUE VA A UTILIZAR, SIGA LAS MEDIDAS DE SEGURIDAD DE SU SUPERVISOR.

LISEZ ET COMPRENEZ LES INSTRUCTIONS DU FABRICANT EN CE QUI REGARDE CET EQUIPMENT ET LES PRODUITS A ETRE EMPLOYES ET SUIVEZ LES PROCEDURES DE SECURITE DE VOTRE EMPLOYEUR.

LESEN SIE UND BEFOLGEN SIE DIE BETRIEBSANLEITUNG DER ANLAGE UND DEN ELEKTRODENEINSATZ DES HERSTELLERS. DIE UNFALLVERHÜTUNGSVORSCHRIFTEN DES ARBEITGEBERS SIND EBENFALLS ZU BEACHTEN.

			
<ul style="list-style-type: none"> ● Keep your head out of fumes. ● Use ventilation or exhaust to remove fumes from breathing zone. 	<ul style="list-style-type: none"> ● Turn power off before servicing. 	<ul style="list-style-type: none"> ● Do not operate with panel open or guards off. 	WARNING
<ul style="list-style-type: none"> ● Los humos fuera de la zona de respiración. ● Mantenga la cabeza fuera de los humos. Utilice ventilación o aspiración para gases. 	<ul style="list-style-type: none"> ● Desconectar el cable de alimentación de poder de la máquina antes de iniciar cualquier servicio. 	<ul style="list-style-type: none"> ● No operar con panel abierto o guardas quitadas. 	Spanish AVISO DE PRECAUCION
<ul style="list-style-type: none"> ● Gardez la tête à l'écart des fumées. ● Utilisez un ventilateur ou un aspirateur pour ôter les fumées des zones de travail. 	<ul style="list-style-type: none"> ● Débranchez le courant avant l'entretien. 	<ul style="list-style-type: none"> ● N'opérez pas avec les panneaux ouverts ou avec les dispositifs de protection enlevés. 	French ATTENTION
<ul style="list-style-type: none"> ● Vermeiden Sie das Einatmen von Schweißrauch! ● Sorgen Sie für gute Be- und Entlüftung des Arbeitsplatzes! 	<ul style="list-style-type: none"> ● Strom vor Wartungsarbeiten abschalten! (Netzstrom völlig öffnen; Maschine anhalten!) 	<ul style="list-style-type: none"> ● Anlage nie ohne Schutzgehäuse oder Innenschutzverkleidung in Betrieb setzen! 	German WARNUNG
<ul style="list-style-type: none"> ● Mantenha seu rosto da fumaça. ● Use ventilação e exaustão para remover fumo da zona respiratória. 	<ul style="list-style-type: none"> ● Não opere com as tampas removidas. ● Desligue a corrente antes de fazer serviço. ● Não toque as partes elétricas nuas. 	<ul style="list-style-type: none"> ● Mantenha-se afastado das partes moventes. ● Não opere com os painéis abertos ou guardas removidas. 	Portuguese ATENÇÃO
<ul style="list-style-type: none"> ● ヒュームから顔を離すようにして下さい。 ● 換気や排煙に十分留意して下さい。 	<ul style="list-style-type: none"> ● メンテナンス・サービスに取りかかる際には、まず電源スイッチを必ず切って下さい。 	<ul style="list-style-type: none"> ● パネルやカバーを取り外したまま機械操作をしないで下さい。 	Japanese 注意事項
<ul style="list-style-type: none"> ● 頭部遠離煙霧。 ● 在呼吸區使用通風或排風器除煙。 	<ul style="list-style-type: none"> ● 維修前切斷電源。 	<ul style="list-style-type: none"> ● 儀表板打開或沒有安全罩時不準作業。 	Chinese 警告
<ul style="list-style-type: none"> ● 얼굴로부터 용접가스를 멀리하십시오. ● 호흡지역으로부터 용접가스를 제거하기 위해 가스제거기나 통풍기를 사용하십시오. 	<ul style="list-style-type: none"> ● 보수전에 전원을 차단하십시오. 	<ul style="list-style-type: none"> ● 판넬이 열린 상태로 작동치 마십시오. 	Korean 위험
<ul style="list-style-type: none"> ● بعد رأسك بعيداً عن الدخان. ● استعمل التهوية أو جهاز ضغط الدخان للخارج لكي تبعد الدخان عن المنطقة التي تتنفس فيها. 	<ul style="list-style-type: none"> ● اقطع التيار الكهربائي قبل القيام بأية صيانة. 	<ul style="list-style-type: none"> ● لا تشغيل هذا الجهاز إذا كانت الاغطية الحديدية الوالفة ليست عليه. 	Arabic تحذير

LEIA E COMPREENDA AS INSTRUÇÕES DO FABRICANTE PARA ESTE EQUIPAMENTO E AS PARTES DE USO, E SIGA AS PRÁTICAS DE SEGURANÇA DO EMPREGADOR.

使う機械や溶材のメーカーの指示書をよく読み、まず理解して下さい。そして貴社の安全規定に従って下さい。

請詳細閱讀並理解製造廠提供的說明以及應該使用的銀焊材料，並請遵守貴方的有關勞動保護規定。

이 제품에 동봉된 작업지침서를 숙지하시고 귀사의 작업자 안전수칙을 준수하시기 바랍니다.

اقرأ بتمعن وافهم تعليمات المصنع المنتج لهذه المعدات والمواد قبل استعمالها واتبع تعليمات الوقاية لصاحب العمل.

LIMITED WARRANTY

Effective August 1, 2010

This warranty supersedes all previous MK Products warranties and is exclusive, with no other guarantees or warranties expressed or implied.

LIMITED WARRANTY - MK Products Inc., Irvine, California warrants that all new and unused equipment furnished by MK Products is free from defects in workmanship and material as of the time and place of delivery by MK Products. No warranty is made by MK Products with respect to trade accessories or other items manufactured by others. Such trade accessories and other items are sold subject to the warranties of their respective manufacturers, if any.

MK Products' warranty does not apply to components having normal useful life of less than one (1) year, such as relay points, wire conduit, tungsten, and welding gun parts that come in contact with the welding wire, including gas cups, gas cup insulators, and contact tips where failure does not result from defect in workmanship or material.

MK Products shall, exclusively remedy the limited warranty or any duties with respect to the quality of goods, based upon the following options:

- (1) repair
- (2) replacement
- (3) where authorized in writing by MK Products, the reasonable cost of repair or replacement at our Irvine, California plant.

As a matter of general policy only, MK Products may honor an original user's warranty claims on warranted equipment in the event of failure resulting from a defect within the following periods from the date of delivery of equipment to the original user:

- 1. Power Supplies and Wire Feed Cabinets 3 years
- 2. Weldheads, Coolers, Positioners, and Push-Pull Guns ...1 year
- 3. Spool Guns, and Spool Gun Modules 180 days
- 4. Repairs/Exchanges/Parts 90 days

Classification of any item into the foregoing categories shall be at the sole discretion of MK Products. Notification of any failure must be made in writing within 30 days of such failure.

A copy of the invoice showing the date of sale must accompany products returned for warranty repair or replacement.

All equipment returned to MK Products for service must be properly packaged to guard against damage from shipping. MK Products will not be responsible for any damages resulting from shipping.

Normal surface transportation charges (one way) for products returned for warranty repair or replacement will be borne by MK Products, except for products sold to foreign markets.

ANY EXPRESS WARRANTY NOT PROVIDED HEREIN AND ANY IMPLIED WARRANTY, GUARANTY, OR REPRESENTATION AS TO PERFORMANCE, AND ANY REMEDY FOR BREACH OF CONTRACT WHICH, BUT FOR THIS PROVISION, MIGHT ARISE BY IMPLICATION, OPERATION OF LAW, CUSTOM OF TRADE, OR COURSE OF DEALING, INCLUDING ANY IMPLIED WARRANTY OF MERCHANTABILITY OR OF FITNESS FOR PARTICULAR PURPOSE, WITH RESPECT TO ANY AND ALL EQUIPMENT FURNISHED BY MK PRODUCTS, IS EXCLUDED AND DISCLAIMED BY MK PRODUCTS.

EXCEPT AS EXPRESSLY PROVIDED BY MK PRODUCTS IN WRITING, MK'S PRODUCTS ARE INTENDED FOR ULTIMATE PURCHASE BY COMMERCIAL/INDUSTRIAL USERS AND FOR OPERATION BY PERSONS TRAINED AND EXPERIENCED IN THE USE AND MAINTENANCE OF WELDING EQUIPMENT AND NOT FOR CONSUMERS OR CONSUMER USE. MK PRODUCTS' WARRANTIES DO NOT EXTEND TO, AND NO RE-SELLER IS AUTHORIZED TO EXTEND MK PRODUCTS' WARRANTIES TO ANY CONSUMER.

USE OF OTHER THAN **GENUINE** MK PRODUCTS' CONSUMABLES, PARTS, AND ACCESSORIES MAY INVALIDATE YOUR PRODUCT WARRANTY.



16882 Armstrong Ave.
Irvine, CA 92606
Tel (949) 863-1234
Fax (949) 474-1428
www.mkproducts.com

August 1, 2010

THIS PAGE INTENTIONALLY BLANK



16882 Armstrong Ave.

Irvine, CA 92606

Tel (949)863-1234 Fax (949)474-1428

www.mkproducts.com